

CHAPTER 16
SUBDIVISION REGULATION ORDINANCE

[Adopted eff. 6/9/68, under R. S. 1964, T. 30, Sec. 4956] (With revisions eff. 7/13/93 and subsequent revisions eff. 2/12/94 , 7/13/94, 1/10/96 and 12/10/03)]

Article I.	Purpose, Authority, Scope, Definitions	1
Sec. 16-1-1.	Purpose	1
Sec. 16-1-2.	Authority	3
Sec. 16-1-3.	Scope	3
Sec. 16-1-4.	Definitions	3
Article II.	Review Procedures	6
Sec. 16-2-1.	General Procedures	6
Sec. 16-2-2.	Pre-Application Process	6
Sec. 16-2-3.	Review & Approval of Minor Subdivision Plans	6
Sec. 16-2-4.	Review & Approval of Major Subdivision Plans	8
Sec. 16-2-5.	Amendments to Previously Approved Subdivision Plans	14
Sec. 16-2-6.	Inspection of Required Improvements	14
Article III.	Standards	16
Sec. 16-3-1.	General Standards of Subdivision Design	16
Sec. 16-3-2.	Road Design & Construction Design	20
Sec. 16-3-3.	Design of Other Improvements	35
Sec. 16-3-4.	Additional Standards	36
Sec. 16-3-5.	Waivers	36
Sec. 16-3-6.	Legal Provisions	36
Appendix A.		37
Appendix B.		40
Appendix C.		44

ARTICLE I. Purpose, Authority, Scope, Definitions.

Sec. 16-1-1. Purpose. This ordinance is designed to promote the health, safety, convenience and general welfare of the Inhabitants of the Town of Cape Elizabeth by encouraging and ensuring sound planning, the use of the environment under healthful conditions, the imaginative and orderly use of land, compliance with the goals and objectives of the Comprehensive Plan, and development that fits harmoniously into the existing natural environment and rural character. ~~To this end, in evaluating any proposed subdivision of land within the Town of Cape Elizabeth, the Planning Board shall determine whether such subdivision will meet the standards set forth in this Chapter and:~~

- ~~(a) Will not result in undue water or air pollution. In making this determination it shall consider at least: the elevation of land above sea level and its relation to the flood plains, the nature of soils and sub-soils and their ability too adequately support waste disposal; the slope of the land and its effect on effluents; the~~

- availability of streams for disposal of effluents; and the applicable state and local health and water resources regulations;
- ~~(b) Has sufficient water available for the reasonably foreseeable needs of the subdivision;~~
 - ~~(c) Will not cause an unreasonable burden on an existing public water supply, if one is to be utilized;~~
 - ~~(d) Will not cause an unreasonable soil erosion or reduction in the capacity of the land to hold water so that a dangerous or unhealthy condition may result;~~
 - ~~(e) Will not cause unreasonable highway or public road congestion or unsafe conditions with respect to use of the highways or public roads, alone or in conjunction with existing or contemplated road use;~~
 - ~~(f) Will provide for adequate sewage waste disposal;~~
 - ~~(g) Will not cause an unreasonable burden on the ability of a municipality to dispose of solid waste and sewage if municipal services are to be utilized;~~
 - ~~(h) Will not have an undue adverse effect on the scenic or natural beauty of the area, scenic vistas, aesthetics, wildlife habitat, historic sites or rare and irreplaceable natural areas; or any public rights for physical or visual access to the shoreline;~~
 - ~~(i) Is in conformance with these Subdivision Regulations, the Zoning Ordinance, Comprehensive Plan for the Town of Cape Elizabeth and the requirements for building and development in flood hazard areas set forth in Article VI of Chapter 6 of this Code of Ordinances;~~
 - ~~(j) The applicant has adequate financial and technical capacity to meet the above stated standards;~~
 - ~~(k) Whenever situated, in whole or in part, within 250 feet of any water body, stream, brook, wetland as defined in the Zoning Ordinance, or tidal waters, will not adversely affect the quality of such body of water or unreasonably affect the shoreline of such body of water;~~
 - ~~(l) Will not, alone or in conjunction with existing activities, adversely affect the quality of ground water;~~
 - ~~(m) The applicant will determine, based on the Federal Emergency Management Agency's Flood Boundary and Floodway Maps and Flood Insurance Rate Maps, whether the subdivision is in a flood-prone area. If the subdivision, or any part of it, is in such an area, the applicant will determine the 100-year flood elevation and flood hazard boundaries within the subdivision. The proposed subdivision plan~~

~~shall include a condition of plat approval requiring that principal structures on lots in the subdivision shall be constructed with their lowest floor, including the basement, at least one foot above the 100-year flood elevation; and~~

~~(n) Will promote energy conservation and efficiency.~~

Sec. 16-1-2. Authority These regulations shall apply to all land within the limits of the Town of Cape Elizabeth, Cumberland County, Maine. They shall be administered by the Planning Board of the Town of Cape Elizabeth, hereinafter called “the Board”, and the Town’s planning and code enforcement staff, and the registered professional engineer employed or retained by the Town who shall be its lawful agents.

Sec. 16-1-3 Scope.

- (a) Any person, firm, corporation or other legal entity proposing to sell, lease or convey, or to offer or agree to sell, lease or convey, any land in a subdivision any portion of which is within the limits of the Town of Cape Elizabeth, ~~including without limitation any unit within multiplex housing, as defined herein,~~ shall first submit such subdivision for approval by the Board in accordance with ~~this~~ these Regulations and shall record in the Cumberland County Registry of Deeds a plan thereof bearing the approval of the Planning Board.
- (b) No utility installations; no ditching, grading or construction of roads; no grading of land or lots; and no construction of buildings shall be done on any part of the proposed subdivision until a subdivision application has been submitted, reviewed and finally approved as provided by this Ordinance.

Sec. 16-1-4 Definitions.

In general, words and terms used in ~~this ordinance~~ these Regulations shall have their customary dictionary meanings, but the following words and terms as used in ~~this ordinance~~ these Regulations are defined as follows:

“**Applicant**” - the record owner, or a person having an interest in the land either through written option or contract.

“**Access Road**” - any road which includes (1) an 18’ wide traveled way, (2) deeded and actual rights of public emergency access, and (3) year-round maintenance, including snow plowing of the road, the responsibility of which is documented in a binding written agreement if the road is not located within a public right-of-way.

“**Arterial**” - a road which is a major link with other communities. This road typically averages in excess of 3,000 trips per day with an average length of each trip of more than one mile. Arterials accommodate residential, agricultural and most of the Town’s commercial development. Direct access by residential development should be discouraged, and commercial access should be combined with adjacent commercial uses where feasible.

“**Board**” - shall refer to Planning Board.

“Building Envelope” - The area within a lot where the main and accessory buildings shall be located.

“Cluster Development” - A type of subdivision development for single family detached dwellings or a combination of single-family detached dwellings and multiplex dwellings where lot sizes, lot widths, and building setbacks are reduced below the minimum requirements of this ordinance and the land gained thereby is set aside as open space.

“Code Enforcement Administrator/Officer” - the staff person designated to administer the Town’s code enforcement operations.

“Collector” - a road which collects traffic from the most densely settled areas and typically connects to an adjacent community. This road averages in excess of 2,000 trips per day with an average length of each trip over more than one mile. Collectors are located in areas with a dense, suburban pattern of development. The design of collectors must provide heavy traffic flow capacity and protect sensitive scenic areas and neighborhoods. Direct access by single driveway should be discouraged.

“Dead-end road” - a road with a single, common means of ingress and egress.
[Rev. eff. 7/13/94]

“Ditch” - a channel for conveying surface water outside the traveled way.

“Dwelling unit” - any part of a structure which, through sale or lease, is intended for human habitation, including single-family and multi-family housing, condominiums, apartments and time-share units.

“Emergency Access Lane” - a public or private paved road with a minimum width of 18’ which is not open to through vehicular traffic. This type of road may provide secondary emergency access to an area served by a dead-end road. [Rev. eff. 6/12/91]

“Esplanade” - a landscaped strip of land located between a road and a sidewalk or between two roads.

“Feeder” - a road which connects local roads to other roads. This road is typically densely developed and serves more than 100 dwellings or approximately 1,000 trips per day. Feeders primarily serve residential traffic where access by single driveway is common.

“Final Approval” - The status of an application once there has been a Planning Board Decision, any conditions on the approval have been met, the recording plat has been signed and a performance guarantee has been accepted by the Town.

“Gutter” - a channel for conveying surface water along the edge of pavement.

“Local Road” - a road which provides direct access to adjacent residential land or the Town center area. The local road is the most common road classification and carries a low volume of trips in residential areas, although higher volumes are also common in the Town center area. Local roads should be designed for slow speeds and frequent pedestrian travel.

“**Lot**” - an area of land in one ownership, regardless of the dates or sources of acquisition thereof and regardless of the buildings and uses existing thereon, having definite boundaries by recorded plan or deed and having an area of less than 40 acres.

“**Manufactured Housing Unit**” - structures, transportable in one or two sections, which were constructed in a manufacturing facility and are transported to a building site and designed to be used as dwellings when connected to the required utilities, including the plumbing, heating, air conditioning and electrical systems contained therein.

“**Manufactured Housing Park**” - a parcel of land under unified ownership designed and/or used to accommodate three or more manufactured housing units.

“**Manufactured Housing Park Lot**” - the area of land on which an individual home is situated within a manufactured housing park and which is reserved for use by the occupants of that home.

“**Multiplex Housing**” - attached dwelling units, as defined in the Zoning Ordinance (Chapter 19).

“**Performance Guarantee**” - any security that may be accepted by the Town to assure that improvements required as part of an application for development will be completed in compliance with the approved plans.

“**Planner**” - that person designated from time to time by the Town to assist the Planning Board in its subdivision and site plan review.

“**Planning Board Decision**” - the Planning Board vote to approve or conditionally approve the preliminary or final plan.

“**Principal Structure**” - any building other than one which is used for purposes wholly incidental or accessory to the use of another building on the same premises.

“**Private Road**” - a road or way which provides access to more than one principal structure and which is not owned by the Town.

“**Resubdivision**” - the replatting of all or part of the land included in a subdivision plan already approved by the Planning Board.

“**Road**” - a public or private way for vehicular traffic however designated, serving more than one residential unit or more than one lot.

“**Rural Connector**” - A road which handles trips between different parts of Town and connects rural residential development to arterials. This road typically carries less than 1,000 trips per day with an average length of more than one mile. Rural connectors are located in primarily rural residential areas and the rural character should be maintained. Access by residential 7 development should preferably be by a local road, but may be from a single driveway.

“**Sight Distance**” - continuous and clear sight distance that meets the minimum requirements in Section 16-3-2 (a) (1) of this Ordinance.

“**Site Improvement**” - all changes and construction required of a development to be in compliance with Planning Board approval and Town Standards.

“Structure” - new structure or structures includes any structures for which construction begins on or after September 23, 1988. The area included in the expansion of an existing structure is deemed to be a new structure for the purposes of the Subdivision Ordinance.

“Subdivision” - the division of a tract or parcel of land into 3 or more lots within any 5 year period, which period begins after September 22, 1971, whether accomplished by sale, lease, development, buildings or otherwise. The term “subdivision” also includes the division of a new structure or structures on a tract or parcel of land into 3 or more dwelling units within a 5-year period, the construction or placement of 3 or more dwelling units on a single tract or parcel of and the division of an existing structure or structures previously used for commercial or industrial use into 3 or more dwelling units within a 5-year period., provided that a division accomplished by devise, condemnation, order of court, gift to a person related to the donor by blood, marriage or adoption, unless the intent of such gift is to avoid the objectives of this Ordinance, or by transfer of any interest in land to the owner of land abutting thereon, shall not be considered to create a lot or lots for the purpose of this Ordinance.

A. In determining whether a tract or parcel of land is divided into 3 or more lots, the first dividing of such tract or parcel, unless otherwise exempted herein, shall be is considered to create the first 2 lots and the next dividing of either of said first two lots, by whomever accomplished, unless otherwise exempted herein, shall be is considered to create a 3rd lot, unless:

(1) Both such dividings are accomplished by a applicant subdivider who has shall have retained one of the such lots for his the subdivider’s own use as a single family residence for a period of at least 5 years prior to such immediately preceding the 2nd division dividing; or

(2) The division of the tract or parcel is otherwise exempt under subsection D below.

B. The dividing of a tract or parcel of land and the lot or lots so made, which dividing or lots when made are not subject to the Subdivision Ordinance, do not become subject to the Subdivision Ordinance by the subsequent dividing of that tract or parcel of land or any portion of that tract or parcel of land. The municipal reviewing authority shall consider the existence of the previously created lot or lots in reviewing a proposed subdivision created by a subsequent dividing.

C. -A lot-Lots of 40 or more acres shall not be counted as lots when the lot is located entirely outside of the Shoreland Performance Overlay District.-

D. Exceptions.

(1) A division accomplished by devise does not create a lot or lots for the purposes of this definition, unless the intent of the transferor is to avoid the objectives of the Subdivision Ordinance.

(2) A division accomplished by condemnation does not create a lot or lots for the purposes of this definition, unless the intent of the transferor is to avoid the objectives of the Subdivision Ordinance.

- (3) A division accomplished by order of court does not create a lot or lots for the purposes of this definition, unless the intent of the transferor is to avoid the objectives of the Subdivision Ordinance.
- (4) A division accomplished by gift to a person related to the donor of an interest in property held by the donor for a continuous period of 5 years prior to the division by gift does not create a lot or lots for the purposes of this definition, unless the intent of the transferor is to avoid the objectives of the Subdivision Ordinance. If the real estate exempt under this definition is transferred within 5 years to another person not related to the donor of the exempt real estate as provided in this paragraph, then the previously exempt division creates a lot or lots for the purposes of the Subdivision Ordinance. "Person related to the donor" means a spouse, parent, grandparent, brother, sister, child or grandchild related by blood, marriage or adoption. A gift under this definition can not be given for consideration that is more than 1/2 the assessed value of the real estate.
- (5) A division accomplished by a gift to a municipality if that municipality accepts the gift does not create a lot or lots for the purposes of this definition, unless the intent of the transferor is to avoid the objectives of the Subdivision Ordinance.
- (6) A division accomplished by the transfer of any interest in land to the owners of land abutting that land does not create a separate lot does not create a lot or lots for the purposes of this definition, unless the intent of the transferor is to avoid the objectives of the Subdivision Ordinance. If the real estate exempt under this paragraph is transferred within 5 years to another person without all of the merged land, then the previously exempt division creates a lot or lots for the purposes of the Subdivision Ordinance.
- (7) The grant of a bona fide security interest in an entire lot that has been exempted from the definition of subdivision under subsection D above, or subsequent transfer of that entire lot by the original holder of the security interest or that person's successor in interest, does not create a lot for the purposes of this definition, unless the intent of the transferor is to avoid the objectives of the Subdivision Ordinance.
- E. The division of a tract or parcel of land into 3 or more lots and upon each of which lots permanent dwelling structures legally existed before September 23, 1971 is not a subdivision.
- F. In determining the number of dwelling units in a structure, the provisions of the Subdivision Ordinance regarding the determination of the number of lots apply, including exemptions from the definition of a subdivision of land.
- G. Notwithstanding the provisions of the Subdivision Ordinance, leased dwelling units are not subject to subdivision review if the municipal reviewing authority has determined that the units are otherwise subject to Site Plan Review under the Zoning Ordinance. For the purposes of this section, a tract or parcel of land is defined as all contiguous land in the same ownership, provided that lands located

~~on opposite sides of a public or private road shall be considered each a separate tract or parcel of land unless such road was established by the owner of land on both sides thereof.~~

“Subdivision Major” - A subdivision containing more than five lots, or requiring substantial extension of municipal facilities, or requiring any new public road~~street extension~~, or falling under the cluster provisions of the Zoning Ordinance, or multiplex housing as defined in the Zoning Ordinance or a manufactured housing park as defined herein.

“Subdivision Minor” - A subdivision containing not more than five lots and is not otherwise defined above as a major subdivision.

“Through road” - a road with more than one means of ingress or egress. Both means of ingress and egress must, at a minimum, meet the standards of an access road. [Rev. eff. 7/13/94]

“Tract or parcel of land”- Tract or parcel of land means all contiguous land in the same ownership, except that lands located on opposite sides of a public or private road are considered each a separate tract or parcel of land unless the road was established by the owner of land on both sides of the road after September 22, 1971.

“Traveled Way” - that portion of a right-of-way which is regularly used for vehicular traffic.

Article II. Review Procedures

Sec. 16-2-1. General Procedures. In all stages of the subdivision review process, the burden of proof shall be upon the applicant proposing the subdivision. The Planning Board shall maintain a permanent record of all its meetings, proceedings and correspondence.

Sec. 16-2-2. Pre-Application Process. Prior to submitting an application for subdivision review, the applicant shall meet with the Planning Board at a workshop at least once to discuss the proposal generally, acquaint the board with the nature of the proposal and the location, topography and other attributes of its site, review potential submission waivers and obtain preliminary classification of the proposal as either a minor or major subdivision. All abutting property owners, and any abutting municipalities, of the proposed subdivision shall be notified by mail of the Planning Board workshop [in accordance with the procedures in Sec. 16-2-3(a)(3)]. Such notice shall include the location and general description of the proposed subdivision.

Sec. 16-2-3. Review and Approval of Minor Subdivisions

(a) Procedures.

1. Formal Submission. The subdivision applicant or an agent duly authorized in writing, shall submit to the ~~Town~~ Planner a subdivision application for consideration by the Planning Board together with the fee therefore as prescribed by the Town Council, and fourteen (14) complete copies of the proposed subdivision plans and materials. All plans and materials shall be submitted at least 18 calendar days prior to the

Board's next scheduled meeting. Prior to the first meeting with the Planning Board, the applicant shall also establish a Review Escrow Account under the terms in Sec. 16-2-4 (a) (1).

2. Preliminary Completeness. Within thirty (30) days of the receipt of a ~~final~~ subdivision application and accompanying materials, the ~~Town~~ Planner, in consultation with the Planning Board Chairperson or Vice Chairperson, shall make a preliminary determination ~~of completeness regarding whether the application is complete or incomplete.~~ If the application is preliminarily determined to be incomplete, the ~~Town~~ Planner shall so notify the applicant in writing and shall list in the written determination the materials that must be submitted in order to make the application complete. If an applicant fails to submit a complete application within four (4) months of the date of the ~~Town~~ Planner's preliminary written determination, the application shall be deemed withdrawn. When the ~~Town~~ Planner makes the preliminary determination that an application is complete, the application shall be scheduled for consideration at the next available Planning Board meeting. Once scheduled, the ~~Town~~ Planner shall promptly notify the applicant of the time and place of such meeting. No action taken by the ~~Town~~ Planner, either alone or in consultation with the Planning Board Chairperson or Vice Chairperson, with respect to reviewing a subdivision application, shall result in an application being deemed pending for the purposes of Title 1, M.R.S.A. Sec. 302. The ~~Town~~ Planner, either alone or in consultation with the Planning Board Chairperson or Vice Chairperson, shall have no authority to review the substance of a subdivision application to determine whether it complies with the subdivision review criteria.

3. Public Notice. Once a Planning Board meeting is scheduled, the ~~Town~~ Planner shall also cause notice to be given by mail to the owners, as currently listed by the Town Tax Assessor, of all properties located within 1,000 feet of the proposed ~~subdivision project~~ or of the 25 properties located nearest to it, whichever number is less, but in no case less than all the abutters to the project site. ~~If the project a proposed subdivision abuts an adjacent municipality, the Town Planner shall notify the adjacent municipality's planning staff and request that all pertinent property owners be notified of the minor subdivision project proposal.~~

If the Planning Board meeting will include a public hearing on the project, mailed notice shall be provided to abutters as described above. In addition, the Planner shall cause notice of the date, time and place of the hearing to be published at least 2 times, in a newspaper having general circulation in the Town of Cape Elizabeth. The date of the first publication must be at least 7 days before the public hearing.

43. Planning Board Completeness. At its first meeting for consideration of an application for approval of a subdivision, ~~the Planning Board shall issue to the applicant a dated receipt for such application.~~ the Planning Board shall ~~then~~ determine whether the application is complete or incomplete, ~~and shall notify the applicant of the Board's determination in writing within 30 days of the date that the receipt is issued.~~ If the application is determined to be incomplete, the Planning Board shall list in its written determination the materials

that must be submitted in order to make the application complete. Within 7 days of the first regular meeting, the Planning Board shall provide to the applicant a dated letter acknowledging receipt of the application and the Planning Board's determination of completeness. ~~When the application is determined to be complete, the Planning Board shall notify the applicant and begin full evaluation of the proposed subdivision.~~ If an applicant fails to submit a complete application within 4 months of the Planning Board letter issued receipt or within four months of the written determination of the ~~Town~~ Planner, the application shall be deemed withdrawn, unless said time limitation is otherwise extended by the Planning Board for good cause. When the application is deemed complete, the Planning Board may begin review of the proposed subdivision.

54. Site Walk. A site walk by the Planning Board may be scheduled, ~~once the dated receipt for an application is issued.~~ Additional site walks may be scheduled, if deemed necessary by the Board.
65. Minor Subdivision Classification. At its first meeting for application consideration, the Planning Board shall finalize classification of the proposed subdivision as either a minor or major subdivision. The Board at this meeting may require a minor subdivision to comply with some or all of the requirements specified for major subdivisions where the Board finds it necessary to determine compliance with the standards set forth in this Chapter.
76. Public Hearing. The Planning Board, at its discretion, may hold a public hearing on a minor subdivision. If the Board determines to hold a hearing, it shall hold the hearing within 30 days of the date that the application is determined to be complete and shall provide public notice in accordance with Section ~~16-2-4 (a) (7)~~ 16-2-3(a)(3) of this Chapter.
87. Planning Board Decision. The Planning Board shall approve, with conditions, or disapprove the ~~Final~~ Subdivision Plan: (i) within 60 days from the date of the date that the application is determined to be complete, of (ii) within such other time that may be mutually agreed upon by both the Planning Board and the applicant. The Planning Board shall specify in writing its decision and findings of fact regarding the decision.
98. Performance Guarantee. ~~The If the Board determines that security for performance is required for the completion of any proposed site improvements, the procedures and standards of Section 16-2-4 (c) (7) (A) shall apply and be met before construction of the subdivision may begin.~~ final plan approval can be given.

b) Submission Requirements . Minor Subdivision Plan submissions shall conform to the standards and requirements contained in Appendix A of this Ordinance.

(c) Final Plan Recording Approval & Filing.

1. Signature and Recording. Upon satisfaction of any conditions placed on the Planning Board approval, ~~completion of the requirements above,~~ the Final Plan shall be signed by a majority of the Planning Board and shall be recorded by the applicant in the Cumberland County Registry of Deeds. There shall be no sale of lots, issuance of building permits, nor site work, however, until the required performance guarantee has been approved in accordance with Sec. 16-2-4 (c)(7)(A).

2. Approval Expiration. An approval of any subdivision plan not filed for recording within 90 days after the Planning Board Decision shall become null and void. The applicant may request, prior to the expiration date, that the Planning Board grant an extension due to the particular circumstances of the applicant, which extension shall not exceed an additional period of ninety (90) days. ~~A note referencing this time provision shall be placed upon the Final Plan, provided the failure to reverence this provision shall in no way limit the effect of this provision.~~ The developer shall provide the ~~Planner~~Code Enforcement Administrator with the plan book number and page number upon recording of the subdivision plan and ~~three~~two copies of the final recorded plans with the signatures of the Planning Board.

Sec. 16-2-4. Review and Approval of Major Subdivision Plans.

(a) Preliminary Plan Procedures.

1. The subdivision applicant, or an agent duly authorized in writing, shall submit to the Town Planner a subdivision application for consideration by the Planning Board together with the fee therefore as prescribed by the Town Council, and fourteen (14) complete copies of the proposed subdivision plans and materials. All plans and materials shall be submitted at least 18 calendar days prior to the Board's next scheduled meeting. In addition to the application fees set by the Town Council for all subdivision applications, all applications for preliminary plan approval for Major Subdivisions as herein defined shall be accompanied by a Review Escrow Fee to defray the Town's costs for application review by the Town Engineer and other independent consulting services. The fee shall be recommended by the Town Engineer and approved by the Town Manager upon initial review of the application and paid to the Town by the applicant prior to the first meeting with the Planning Board. The fee shall be deposited in a Review Escrow account designated for that subdivision application. If the costs of application review by the Town Engineer and/or other consulting services exceed the amount of the Review Escrow Account, the applicant shall pay an additional fee to the Town which shall be recommended by the Town Engineer and approved by the Town Manager based upon the status of the application. Any balance in the account remaining ninety (90) days after a final decision on the subdivision application by the Board shall be returned to the applicant unless there is an appeal or other legal action pending with respect to the Planning Board's approval of the subdivision. All interest from the Review Escrow Account shall accrue to the account and shall be applied toward the Town's cost in reviewing the application.
2. Within thirty days of the receipt of a preliminary subdivision application and accompanying materials, the Town Planner, in consultation with the Planning Board Chairperson or Vice Chairperson, shall make a preliminary determination regarding whether the application is complete or incomplete. If the application is preliminarily determined to be incomplete, the Town Planner shall so notify the applicant in writing and shall list in the written determination the materials that must be submitted in order to make the application complete. If an applicant fails to submit a complete application within four (4) months of the date of the Town Planner's preliminary

determination, the application shall be deemed withdrawn. No action taken by the Town Planner, either alone or in consultation with the Planning Board Chairperson or Vice Chairperson, with respect to reviewing a subdivision application, shall result in an application being deemed pending for the purposes of Title 1, M.R.S.A. Section 302. The Town Planner, either alone or in consultation with the Planning Board Chairperson or Vice Chairperson, shall have no authority to review the substance of a subdivision application to determine whether it complies with the subdivision review criteria.

3. When the Town Planner makes the preliminary determination that an application is complete, the application shall be scheduled for consideration at the next available Planning Board Meeting.
4. At its first meeting for consideration of an application for approval of a subdivision, the Planning Board shall issue to the applicant a dated receipt for such application. The Planning Board shall then determine whether the application is complete or incomplete and shall notify the applicant of the Planning Board's determination in writing within 30 days of the date the receipt is issued. If the application is determined to be incomplete, the Planning Board shall list in its written determination the materials that must be submitted in order to make the application complete. When the application is determined to be complete, the Planning Board shall notify the applicant and begin full evaluation of the proposed subdivision. If an applicant fails to submit a complete application within four (4) months of the issued receipt or within four (4) months of the written determination of the Town Planner, the application shall be deemed withdrawn unless said time limitation is otherwise extended by the Planning Board for good cause.
5. A site walk by the Planning Board may be scheduled, once the Planning Board determines the application to be complete. Additional site walks may be scheduled, if deemed necessary by the Planning Board.
6. At its first meeting for application consideration, the Planning Board shall finalize classification of the proposed subdivision as either a major or minor subdivision.
7. Within 30 days of its determination that a subdivision application is complete, the board shall hold a public hearing on such application. It shall cause notice of the date, time, place and purpose of the hearing to be given the applicant and to be published at least twice in a newspaper of general circulation in the Town, the date of the first publication to be at least 7 days prior to the hearing date. It shall also cause notice to be given by mail to the owners, as currently listed by the Town Tax Assessor, of all properties located within 1,000 feet of the proposed subdivision, or of the 25 properties located nearest to it, whichever number is less; any failure of delivery of such mailed notices shall not invalidate the hearing for which given. If a proposed subdivision abuts an adjacent municipality, the Board shall notify the adjacent municipality's planning staff and request that all abutting property owners be notified of the public hearing.

The Board shall so conduct the hearing as to assure full, but not repetitive, public participation. The applicant shall be prepared to respond fully to questioning by the public and the board. The Board may, upon its own motion, extend the hearing once for a period not exceeding 30 days and to a date which shall be announced. The Board may adopt regulations governing the operation of said public hearings and it shall keep minutes thereof.

8. The Planning Board shall approve, approve with conditions, or disapprove the Preliminary Plan.
 - i. within 30 days after the date of the public hearing, or
 - ii. within such other time that may be mutually agreed upon by both the Planning Board and the applicant.

The Planning Board shall specify in writing its findings of fact and the Board's decision. Terms and conditions imposed by the Board shall be those it deems advisable to satisfy the criteria listed in Sec. 16-1-1 (a) through (n) and the design standards set forth in Article III of these Regulations, and to protect and preserve the public's health, safety and general welfare. Such terms and conditions shall include the issuance of any permits or approval required for such subdivision from any federal, state or other local body or authority, and they may include changes in the proposed subdivision or additional materials corroborating matters already presented.

9. Preliminary Plan approval shall not constitute approval of the Final Plan, but rather shall be deemed an expression of approval of the approach submitted on the Preliminary Plan as a guide to preparation of the Final Plan.

(b) Preliminary Plan Submission Requirements .

Preliminary Plan submissions shall conform to the standards and requirements contained in Appendix B of this Ordinance.

(c) Final Plan Procedures .

1. Within six months following the Planning Board's approval or approval with conditions of an applicant's Preliminary Plan, the applicant shall file with the Town Planner for Planning Board consideration, a Final Plan application for the subdivision with fourteen (14) copies of the materials herein prescribed. If such application is not filed within such period, the application shall be deemed withdrawn and shall no longer be considered a pending subdivision application, unless said time limitation is otherwise extended by the Board for good cause. Prior to the first meeting with the Planning Board, the applicant shall also establish a Review Escrow Fee under the terms in Sec. 16-2-4 (a)(1).
2. Prior to submission of the Final Plan application, the applicant shall have fulfilled the following requirements and submitted written evidence of requirement to the Board:
 - (A) Written evidence of the issuance of all permits, licenses and approvals required for the subdivision from any federal, state or other local agency;

- (B) Written evidence of an adequate supply of domestic water, in the form of (i) approval by the Portland Water District, (ii) approval by the appropriate state agency of any proposed central water supply system, or (iii) approval by a registered Maine engineer if individual wells are to be used for building sites, in which latter case the board may also require reports by the appropriate state agency of the results of all water quality tests;
 - (C) Written evidence of (i) the availability of public sewage service for some or all of the lots; or (ii) compliance with the clustered sewer system provisions of Chapter 15, reviewed by the Town Engineer, receipt of a letter from the Maine Department of Human Services, and written approval of the local plumbing inspector; or (iii) municipal approval of the proposed sewage disposal systems, to be designed and installed in compliance with the Town Sewer Ordinance, and which shall require the review and approval by the Town Engineer and the building inspector of the subsoils and of said sewage disposal arrangement;
 - (D) Written evidence of (i) the offer and conditional municipal approval of all roads, sewer lines, drainage easements, proposed public open space, recreation land, and all other facilities proposed to be dedicated to the Town; or (ii) satisfactory agreements, restrictive covenants, deed restrictions, condominium declaration or other documents showing the manner in which private roads, sewer lines and systems, drainage ways, open space, recreation land, and other such common areas and facilities are to be maintained. Written agreements of a dedication to a third party other than the Town must also be submitted and deemed satisfactory by the Board.
3. When the Town Planner makes the preliminary determination, in consultation with the Planning Board Chairperson or Vice Chairperson and in following with the procedure set forth in Section 16-2-4 (a) (2) of this Ordinance, that all materials required to constitute a complete application have been submitted by an applicant, the Town Planner shall schedule consideration of the application for its next available Planning Board meeting. The applicant shall also be promptly notified of the time and place for such meeting.
 4. At its first meeting for consideration of an application for final approval of a subdivision, the Board shall issue to the applicant a dated receipt for such application. The Planning Board shall then determine whether the application is complete or incomplete and shall notify the applicant of the Board's determination in writing 35 days of the date that the receipt is issued. If determined to be incomplete, the Planning Board shall list in its written determination the materials that must be submitted in order to make the application complete. When the application is determined to be complete, the Planning Board shall notify the applicant and begin full evaluation of the proposed subdivision. Any application not determined to be complete within 4 months of the issued receipt date shall be deemed withdrawn and

shall no longer be considered a pending subdivision application, unless said time limitations is otherwise extended by the Board for good cause.

5. The Planning Board may schedule a public hearing on the Final Plan if it considers any changes in the plan sufficient to warrant further public comment. Public notice shall be given in accordance with Section 16-2-4 (a) (6) of this Ordinance.
6. The Planning Board shall set the amount, terms and conditions of a performance guarantee to secure completion of all required public improvements. The applicant shall provide cost estimates of the required improvements, which shall be reviewed and modified if necessary by the Town Engineer.
7. Prior to a Planning Board Decision, the applicant shall:
 - A. Submit to the Planning Board a performance guarantee in the form of a irrevocable letter of credit or escrow account in favor of the Town in an amount based on a detailed estimate prepared by the applicant and reviewed by the Town Engineer accompanied by a schedule of work to be appended to the performance guarantee. The amount shall be set by the Board as sufficient to cover the cost of whichever amount is greater of the following: (i) proper completion of all roads, sewer, water, drainage, open space and other required improvements, or (ii) reasonable restoration of the subdivision tract. The reasonable costs that may be incurred in enforcing the performance guarantee granted to the Town shall also be included in the amount of the performance guarantee including possible legal fees. Such performance guarantee shall be satisfactory to the Town Manager and to the Town Attorney as to the issuer, form sufficiency, surety and manner of execution, provided that all performance guarantees shall contain a provision requiring the issuer or escrow agent to notify the Town Manager in writing of the scheduled expiration date at least thirty (30) days and not more than ninety (90) days in advance of its scheduled expiration date. The Board shall determine the period of not less than one (1) year nor exceeding three (3) years, which shall be stated in the performance guarantee within which required improvements shall be completed. Extensions of the performance guarantee may be granted by the Town Manager for up to three (3) years from the initial expiration date at the request of the applicant for good cause; and
 - B. Present to the Board any survey map required for the subdivision for approval as conforming to the final plans to be noted thereon by signatures of a majority of the board members.
8. The Planning Board shall approve, approve with conditions or disapprove the Final Plan:
 - (i) within 10 days of the date of the public hearing;
 - (ii) within 60 days of the date that the application was determined to be complete if no public hearing is held; or (iii) within such other time that may be mutually agreed upon by both the Planning Board and the applicant.

(d) **Final Plan Submission Requirements.** Final Plan submissions shall conform to the standards and requirements contained in Appendix B of this Ordinance.

(e) **Phasing .** The Planning Board after preliminary plan approval may permit a subdivision to be divided into two or more phases for purposes of final approval. The Board may impose such conditions as it deems necessary to assure the orderly development of the subdivision, to assure that all necessary improvements are made for each separate phase and to assure compliance with this Chapter. The Board shall sign and the applicant shall record a subdivision plat which depicts all phases of the subdivision and which prominently notes that no lots will be sold, nor building permits issued, nor site work commenced in phases for which a performance guarantee has not been approved in accordance with Sec. 16-2-4 (c)(7)(A). The amount, terms and conditions of any performance guarantee shall correspond with the phase or phases scheduled to be constructed and shall otherwise satisfy the procedures and standards of Section 16-2-4 (c) (7) (A). All phases of a subdivision must receive final approval, or shall be identified as an area of possible future development for which Planning Board approval has not been granted.

(f) **Action Upon Approval.** Upon completion of the requirements set forth in Sec. 16-2-4, (d) and (e) above, and notation to that effect upon the final plans, they shall be properly signed by a majority of the Planning Board, and shall be recorded by the applicant in the Cumberland County Registry of Deeds. Any final plans not so recorded within ninety (90) days following the date of Planning Board Decision shall become null and void. The applicant may request, prior to the expiration date, that the Planning Board grant an extension due to particular circumstances of the applicant which extension shall not exceed an additional period of ninety (90) days. Any alteration in a final plan after its approval by the Planning Board has been endorsed thereon shall render such final plan null and void, unless such alteration has received the prior approval of the Planning Board. The applicant shall provide the ~~Town~~ Planner with a receipt from the Registry or Deeds within that time limit stating that the plan has been recorded and giving the book and page number and two copies of the final recorded plan.

Sec. 16-2-5. Amendments to Previously Approved Subdivision Plans

(a) **Scope .** Any change in an approved final subdivision plan including but not limited to lot lines, road layout, and location of structures and improvements must be reviewed and approved by the Board. De minimis changes to an approved subdivision plan may be placed on the Planning Board Consent Agenda at the discretion of the ~~Town~~ Planner.

(b) **De minimis Changes .** De minimis changes shall not include (1) an increase in the number of lots or units, (2) a change to a public or private right-of way or easement, (3) a decrease in proposed buffering or landscaping, or (4) any issue involving a condition placed on the Subdivision approval. Prior to placement on the Consent Agenda, the applicant shall meet with the ~~Town~~ Planner to review the proposed changes and shall provide eight (8) copies of the revised recording plat to the Town Planner at least eighteen (18) days prior to the next regular Planning Board meeting. The decision of the ~~Town~~ Planner to not place an item on the Consent Agenda may be appealed to the Planning Board upon submission of fourteen (14) copies of the

proposed change to the Town Planner eighteen (18) days prior to the next Planning Board meeting.

- (c) **Procedure** . A public hearing may be held concerning a subdivision amendment as prescribed in this Ordinance. The Planning Board may request the submission of information included in Appendix A or B and shall review the subdivision amendment for compliance with the standards in Sec. 16-3-1. All amended plans must make specific reference to the original plan and its recording information, must be signed by a majority of the Planning Board and recorded in the Registry of Deeds within ninety (90) days following the Planning Board Decision. Any amended plan not so filed or recorded within ninety (90) days following the date of the Planning Board decision shall become null and void. The applicant may request, prior to the expiration date, that the Planning Board grant an extension due to the particular circumstances of the applicant, which extension shall not exceed an additional period of ninety (90) days. The applicant shall provide the Town Planner with a receipt from the Registry of Deeds within that time limit stating that the plan has been recorded and giving the book and page numbers and two copies of the final recorded plan.

Sec. 16-2-6. Inspection of Required Improvements All required subdivision improvements for which a performance guarantee shall have been required shall be constructed under the observation of a qualified construction monitor. The construction monitor shall be employed by the Town during the construction phase of the project. Construction monitoring costs shall be borne by the applicant and shall be included in the Inspection Fee in subsection (a) below. The construction monitor shall be on the site during all periods of time when significant construction is taking place. Significant construction shall include (1) embankments, (2) bedding and backfilling of all underground utilities including water lines, (3) installation of storm drainage and associated structures, (4) installation of sanitary sewers and associated structures, (5) roadway subbase material, (6) roadway base material, (7) paving, (8) compaction testing, and (9) sewer and manhole testing. The duties of the construction monitor shall also include (1) review of product reports and material submittals, (2) maintenance of a diary of construction progress, and (3) implementation of remedial measures. Upon completion of construction, the applicant shall present to the Town a set of reproducible mylar record drawings indicating facilities as constructed. The record drawings shall be based on the field logs of the construction monitor and bear the professional seal of a design engineer or landscape architect. The Town Engineer shall have access to the site at all times to review the progress of the work and shall have the authority to review the field logs maintained by the construction monitor. Any deficiencies noted by the Town Engineer shall be brought to the attention of the construction monitor who shall see that remedial measures are taken.

- (a) **Commencement of Construction**. At least ten (10) days prior to commencing construction of required improvements, the applicant shall submit plans to the Town Engineer and shall pay an inspection fee in the amount of five percent (5%) of the cost of the total performance guarantee payable by certified check to the Town of Cape Elizabeth. The inspection fee shall be held by the Town to defray the Town's cost for inspection by the Town Engineer, part-time Town staff, and the construction monitor. Any funds not disbursed for this purpose shall be returned to the applicant

upon release of the performance guarantee. If the costs for inspection exceed the amount of the Inspection Fee, the applicant shall pay an additional fee to the Town which shall be recommended by the Town Engineer and approved by the Town Manager based on the status of the development. The applicant shall notify the Town Manager in writing of the time when he proposes to commence construction of such improvements so that the Town can cause inspections and so that requirements shall be met during construction and to assure satisfactory completion of all improvements and utilities required by the Planning Board. [Revised eff. 11/11/83; Revised eff. 6/13/90]

- (b) Notice of Inspection.** To assure proper inspection of roads and other required improvements, the Town Engineer should be given not less than 24-hour notice by the applicant for inspections required at the following construction stages: (1) before backfilling of any surface water, sanitary sewer, domestic water or other underground lines or improvements, (2) at completion of road subgrades and after installation of gravel surface, (3) at the commencement of paving, loaming, or other final surface preparation, and (4) upon final completion.
- (c) Authority of Town Engineer.** If the Town Engineer shall find upon inspection of required improvements, including an inspection to be done by the engineer before expiration of the performance guarantee, that any of such improvements are not being constructed in accordance with plans and specifications filed by the applicant, or that in his judgment the applicant will be unable to complete the required improvement within the period specified in the performance guarantee, he shall then so notify the applicant and the Town Manager, who shall take all necessary steps to preserve the rights of the Town under the performance guarantee, including authorization to the Town Engineer to stop the construction of said improvements.
- (d) Modification .** If at any time before or during the construction of the required improvements the applicant demonstrates to the satisfaction of the Town Engineer that unforeseen conditions make it desirable to modify the design of such improvements, such engineer may, upon approval by the Planning Board, authorize modifications provided that they are within the spirit and intent of the Planning Board approval and do not constitute waiver or substantial alteration of the function of any improvements required by the Planning Board. The Town Engineer shall issue any authorization under this section in writing, and he shall transmit a copy of such authorization to the Planning Board at its next regular meeting.
- (e) Completion and Acceptance.** As built drawings consisting of two paper copies and one reproducible copy shall be submitted to the Public Works Director prior to public acceptance of public improvements by the Town Council. The as-built drawings shall include an engineer's seal, distances, angles and bearings for complete and accurate determinations of locations on the ground, right-of-way monuments and as set, as-built profiles of the centerlines of traveled ways, ledge elevations encountered during construction and information on the locations, size, materials and elevations of storm drains, sanitary sewers and other underground utility lines, including but not limited to

water, electric, telephone, natural gas, cable television. Upon approval of such as-built plans by the Town Engineer, the applicant may initiate municipal acceptance of any improvements to be dedicated or transferred to the Town, and may initiate any other permanent arrangements for the management, maintenance and operation of any other required improvements. There shall be no final release of any performance guarantee until the as-built plans have been received and approved by the Town Engineer. A set of the final plans shall be submitted to the Town Manager. The applicant shall be required to maintain all improvements and to provide for snow removal on roads and sidewalks, until their acceptance by the Town or the assumption of those responsibilities under such other approved arrangements. (Revised eff 12/10/03)

Article III. Standards

Sec. 16-3-1. ~~General~~ Subdivision Review Standards of Subdivision Design

A subdivision shall meet all of the following standards of review, as determined by the Planning Board.

(a) Pollution

The proposed subdivision will not result in undue water or air pollution. Factors to consider include:

1. The elevation of the land above sea level and its relation to the floodplains.
2. The nature of soils and subsoils and their ability to adequately support waste disposal.
3. The slope of the land and its effect on effluents.
4. The availability of streams for disposal of effluents.
5. The applicable state and local health and water resource rules and regulations.

(b) Sufficient Potable Water

The proposed subdivision has sufficient water available for the reasonably foreseeable needs of the subdivision. If a public water supply will be used, the proposed subdivision will not cause an unreasonable burden on the existing public water supply.

[Possible location of utility standard currently in ordinance]

(c) Erosion

The proposed subdivision will not cause unreasonable soil erosion or a reduction in the land's capacity to hold water so that a dangerous or unhealthy condition results.

(d) Traffic

1. The proposed subdivision will not cause unreasonable highway or public road congestion or unsafe conditions with respect to the use of the highways or public roads existing or proposed, and if the proposed subdivision requires driveways or entrances onto a state or state aid highway located outside the urban compact area of

an urban compact municipality as defined by Title 23, section 745, the Department of Transportation has provided documentation indicating that the driveways or entrances conform to Title 23, section 704 and any rules adopted under that section.

~~(a)~~ 2. Comprehensive Plan. The proposed subdivision road(s) shall conform to the Comprehensive Plan as adopted in whole or in part by the Town Council.

3. Connectivity. The Board may require provision for the projection of roads or for access to adjoining property, whether subdivided or not. The Board may require that access from the subdivision to previously existing or proposed public ways include two means of such vehicular access.

~~(b)~~ 4. Intersection. ~~All roads within a subdivision and roads providing access to a subdivision shall be designed so that they will provide safe vehicular travel and traffic patterns.~~ Access roads shall not be placed within 125 feet of an intersection.

5. Through traffic. The Planning Board may require that local roads be laid out so that their use by through traffic will be discouraged.

~~The board shall require that roads be designed so as to provide safe, convenient and attractive access from the subdivision to previously existing or proposed public ways, which may include two or more means of such vehicular access; it may require that such roads be constructed in their entirety and be finally accepted prior to the issuance of any building permits for construction of dwellings thereon; and it may withhold approval of preliminary or final subdivision plans until such access is provided for by the applicant over his own and/or other abutting property.~~

6. Topography. Roads in the proposed subdivision shall be laid out in an attractive manner, in order to enhance the livability and amenity of the subdivision. Insofar as possible, roads shall conform to existing topography, and high cuts and fills shall be avoided.

7. Block Length. Block lengths shall not exceed 1,000 feet except where a greater length suits the topography or character of the subdivision and does not result in an awkward road pattern or detrimental effect to adjacent property.

8. Lot Access. Each property shall be provided with vehicular access to each lot by an abutting public or private road. A private road shall be protected by a permanent easement which shall conform to the Road Classification Standards Table and which shall be shown on the plan.

9. Sidewalks. The Planning Board may require sidewalks and/or curbing on either or both sides of any road, where they are or may be necessary for maintenance and/or public safety, as determined by the Board.

10. Road Name. Road names shall not be used which will duplicate or may be confused with the names of existing roads. Road names shall be subject to the approval of the Planning Board and Town Council.

(e) Sewage Disposal

The proposed subdivision will provide for adequate sewage disposal and will not cause an unreasonable burden on municipal services if they are utilized. All systems proposed for the disposal of sewage for developments regulated by this Ordinance shall be governed by the provisions of Chapter 15, Sewer Ordinance.

(f) Solid Waste Disposal

The proposed subdivision will provide for adequate disposal of solid waste. The proposed subdivision will not cause an unreasonable burden on the municipality's ability to dispose of solid waste, if municipal services are to be utilized.

(g) Aesthetic, cultural and natural values

The proposed subdivision will not have an undue adverse effect on the scenic or natural beauty of the area, aesthetics, historic sites, significant wildlife habitat identified by the Department of Inland Fisheries and Wildlife or the municipality, or rare and irreplaceable natural areas or any public rights for physical or visual access to the shoreline.

1. Scenic. Consideration shall be given by the applicant and the Planning Board to the impact of the proposed development on scenic vistas and view corridors to and from significant natural features, historic sites, and important topographic features as identified in the Town's Comprehensive Plan. Structures in the proposed subdivision shall not materially obstruct existing scenic vistas and view corridors. The Planning Board may consider the impact of other design features such as building bulk, architectural style and landscaping to ensure visual harmony between views to and from the proposed development and the surrounding neighborhood.

2. Wildlife. The applicant shall make adequate provision for the protection of wildlife habitat and fisheries areas, which may include but are not limited to maintenance of wildlife travel lanes, and the preservation and buffering of wildlife habitat areas from proposed development activities.

3. Natural features. The applicant, whenever practical, shall be required to preserve natural features such as water courses or bodies, existing trees of 10 inches or more in diameter (base height), marshes, swamps or other areas identified on the official wetlands map, open space, scenic points, historic spots, and unusual or striking topographic features which, if preserved, would add to the attractiveness of the subdivision. The Planning Board may require the applicant to dedicate such features to joint ownership and management by the owners of individual lots within the

subdivision. In lieu of dedication to a homeowners association/condominium association, the Planning Board may accept dedication to the Town itself, or an appropriate non-profit third party group or organization, such as the Cape Elizabeth Land Trust. Any dedications must be conveyed through appropriate legal instruments, reviewed by the Town Attorney, and approved by the Town Council.

4. Farmland. All farmland within the proposed subdivision has been identified on maps submitted as part of the application.

(h) Conformity with local ordinances

1. Comprehensive Plan. The proposed subdivision conforms to applicable provisions of the Comprehensive Plan.

2. Zoning Ordinance. The area and width of lots shall conform to the requirements of the Zoning Ordinance. Side lot lines shall be substantially at right angles or radial to road lines.

3. Multiplex Housing. Multiplex housing and cluster developments shall be so designed, sited and laid out as to minimize disturbance of existing topography and ground cover, provide maximum usable natural or improved open space, reflect imaginative use of the site, and be compatible with any surrounding land uses and their character. The minimum lot size and density requirements for any proposed multiplex housing or cluster development shall be as set forth in Sec. 19-3-1 (d) of the Zoning Ordinance.

4. Addressing Ordinance. The numbering of the individual residential dwelling units must be clearly visible and shall be required to be reviewed and approved by the fire chief and police chief. For any development with more than one set of attached or multiplex dwelling units, signs clearly identifying the house numbers in each set of dwelling units shall be required to be placed along the road leading to each set of units and shall be subject to approval of the fire chief and police chief.

(i) Financial and Technical Capability

The subdivider has adequate financial and technical capacity to meet the standards of this section.

OR

The applicant shall demonstrate adequate technical and financial capability to complete the project as proposed. In the case where the applicant asserts that public disclosure of confidential financial information may prove detrimental to the applicant or to the success of the subdivision, the Town Manager may review the financial records of the applicant and recommend to the Planning Board that financial capability is adequate.

(j) Surface Waters

Whenever situation entirely or partially within the watershed of any pond or lake or within 250 feet of any wetland, great pond or river as defined in Title 38, Chapter 3, subchapter I, article 2-B, the proposed subdivision will not adversely affect the quality of that body of water or unreasonably affect the shoreline of that body of water. [The Planning Board may determine that the proposed subdivision will not adversely affect surface water quality if the subdivision has been designed to comply with the Shoreland Performance Overlay District.]

(k) Ground Water

The proposed subdivision will not, alone or in conjunction with existing activities, adversely affect the quality or quantity of ground water.

(l) Flood Areas

Based on the Federal Emergency Management Agency's Flood Boundary and Floodway Maps and Flood Insurance Rate Maps, and information presented by the applicant whether the subdivision is in a flood-prone area. If the subdivision, or any part of it, is in such an area, the subdivider shall determine the 100-year flood elevation and flood hazard boundaries within the subdivision. The proposed subdivision plan must include a condition of plan approval requiring that principal structures in the subdivision will be constructed with their lowest floor, including the basement, at least one foot above the 100-year flood elevation.

____ The Planning Board shall review all subdivision proposals to assure that: (1) they are designed to minimize flood damage; (2) all public utilities and facilities, such as sewer, gas, electrical, and water systems are located, elevated, and constructed to minimize or eliminate flood damage; (3) adequate drainage is provided so as to reduce exposure to flood hazards; and (4) the proposed subdivision otherwise meets the standards of the Town's floodplain requirements.

(m) Wetlands

____ Any proposed alteration of wetlands shall adhere to the requirements and standards of Section 19-2-8 and Section 19-3-9 of the Zoning Ordinance.

(n) Stormwater

The proposed subdivision will provide for adequate stormwater management.

For any subdivision involving more than 10,000 square feet of impervious surface, paving, clearing or vegetative alteration, the provisions and improvements for the control of storm water runoff shall be governed by the provisions of Chapter 18, Article II, Storm Water Control Ordinance. In the case of any subdivision involving

less than 10,000 square feet of such impervious surfaces, where a subdivision is traversed by a stream, drainage way or other watercourse, or where the Planning Board with the advice of the engineer feels that surface water drainage to be created by the subdivision should be controlled for the protection of the subdivision and owners of property abutting it, there shall be provided an easement or drainage right-of way conforming substantially with the lines of such watercourse, and culverts, catch basins or other means of channeling surface water within such subdivision and over the property of owner abutting upon it of such nature, width and location as the Planning Board with the advice of the engineer, deems adequate.

(o) Spaghetti lots prohibited. If any lots in the proposed subdivision have shore frontage on a river, stream, brook, great pond or coastal wetland as these features are defined in Title 38, section 480-B, none of the lots created within the subdivision have a lot depth to shore frontage ratio greater than 5 to 1.

(p) Lake Phosphorus concentration

The long term cumulative effects of the proposed subdivision will not unreasonably increase a great pond's phosphorus concentration during the construction phase and life of the proposed subdivision.

(q) Impact on adjoining municipality. For any proposed subdivision that crosses municipal boundaries, the proposed subdivision will not cause unreasonable traffic congestion or unsafe conditions with respect to the use of existing public ways in an adjoining municipality in which part of the subdivision is located.

(r) Land subject to Liquidation Harvesting

The proposed subdivision is not located on land where timber has been harvested in violation of rules adopted pursuant to Title 12, section 8869, subsection 14 or the violation occurred at least 5 years before the subdivision application has been submitted.

(s) Access to Direct Sunlight

Consideration shall be given by the applicant and the Planning Board to the sensitivity of the proposed subdivision design for the purpose of protecting and assuring access to direct sunlight. Insofar as possible, the subdivision design shall locate structures so as to minimize shading of either existing or proposed structures. The Planning Board may consider restrictive covenants, height restrictions, side yard and setback requirements and other techniques to preserve solar access.

(t) Buffering

~~(e)~~ Plants or other types of vegetative cover shall be preserved or placed throughout and around the perimeter of any proposed subdivision to provide for an adequate buffer,

reduction of noise and lights, separation between the subdivision abutting properties, and enhancement of its appearance.

- (d) Off-road parking lots, storage areas, rubbish disposal areas, or similar improvements exposed to public roads or to residential areas shall be screened by walls, earth berms, fences, or vegetation, and shall be properly landscaped.

(u) Open Space and Pedestrian Connections

The proposed subdivision shall include permanently protected open space accessible to all residents of the subdivision, and as applicable to the public, as further defined below:

~~(q)~~

1. Open Space Impact Fee

- i. Purpose.** In order to accommodate the expected needs of the subdivision for open space and recreational areas without diminishing the community standard of public open space, the applicant shall be required to donate land or a cash contribution in lieu of actual land dedication, or a combination of both, at the option of the Board.
- ii. Community Standard.** Public open space shall include the inventory of open space for which there is legal public access, including:
 - (1) Open space owned by the Town;
 - (2) Open space encumbered by an easement owned by the Town which allows public access;
 - (3) Open space owned by the Cape Elizabeth Land Trust; and
 - (4) Open space encumbered by an easement owned by the Cape Elizabeth Land Trust which allows public access. The Community Standard of public open space shall be defined as the total acreage of open space divided by the Town's population, as of the most recent U.S. Census.
- iii. Land donation .** The required land donation shall be calculated by multiplying the number of lots/units in the proposed subdivision by the average number of persons per household as published in the most recent U.S. Census, and then multiplying the resulting number by the Community Standard of public open space. At least twenty percent (20%) of the land donated shall be land which is not a Resource Protection Zone or buffer and has a slope not to exceed fifteen percent (15%).
- iv. Fee .** If the resulting land dedication would be too small to be useful, or inappropriately located, the Planning Board may require the applicant to pay a fee in lieu of all or part of the required land dedication. The fee shall be calculated by multiplying the amount of acreage which otherwise would have been required to be donated with the proposed subdivision (rounded to the nearest one-hundredth of an acre) by the average fair market value of one acre of vacant land (rounded to

the nearest dollar) determined by the Town Assessor using accepted professional valuation methods.

- v. **Administration** . Land donation and land conveyance shall be consistent with the land included in the town inventory. Open space impact fees shall be segregated from the Town's general revenues and expended only for the acquisition or improvement of public open space. The Town shall refund to the applicant that portion of the collected open space impact fee that is not expended within ten (10) years from the date of receipt. The Community Standard of public open space, average fair market value of one acre of vacant land, and open space impact fee therein derived shall be published in the Fee Schedule approved and periodically updated by the Town Council. The Fee Schedule shall be available for inspection at the office of the Town Clerk. Any required fee shall be paid prior to the commencement of construction of the subdivision and/or issuance of a building permit.

- 2. Pedestrian Connections. Provision of pedestrian easements or other types of pedestrian accessways not less than 10 feet wide may be recommended to the applicant, where a pedestrian accessway would add to the Town's Greenbelt System or where the Planning Board deems it important for pedestrian enjoyment or to provide access to but not limited to schools, playgrounds, shopping centers, recreation areas, open space, trails, shore frontage, and other facilities. Where feasible, the easements shall connect to existing and proposed recreation trails. The Town shall have the right but not the obligation to plow and otherwise maintain such easements.

(†)

- 3. Common Open Space. Common open space, recreation areas or other such areas to be dedicated by the applicant shall be maintained to ensure that its use and enjoyment is not diminished or destroyed, with the applicant submitting written documents identifying which individual, group or organization shall be responsible for said maintenance.

~~(x) All utilities, including but not limited to the provision of water, gas and electricity, and the provision of solid waste disposal, shall be demonstrated to be adequate for the proposed development.~~

Sec. 16-3-2. Road Design and Construction Standards

The purposes of the subdivision road standards are to minimize traffic safety hazards and the cost of municipal maintenance and reconstruction, to insure that roads are consistent with the Town's rural character, to promote a sense of community, and to be consistent with the Comprehensive Plan. The standards shall be flexible where an applicant can demonstrate that alternative approaches will meet the above stated purposes. Roads within a subdivision shall be classified by the Planning Board in accordance with their location and their present and contemplated usage. A road which is likely to be upgraded in classification in the foreseeable future shall be laid out to the standards of the potential future classification. The widths and grades for all subdivision roads shall be determined

in accordance with the **Road Classification Standards Table**, subject to the following qualifications:

1. Where an existing road with right-of-way of less than 50 feet is being extended, the new right-of-way may be the same width as the existing road upon approval by the Planning Board and engineer.
2. Width of right-of-way may be forty (40) feet for a road shorter than 300 feet which ends in a cul-de-sac, upon approval by the Planning Board and engineer.
3. Notwithstanding the **Road Classification Standards Table**, dead-end roads in excess of 1,000 feet in length must comply with Sec. 16-3-2 (a)(9).
4. The minimum required turning radius at road intersections shall provide adequate turning radius for a B-40 vehicle as defined by AASHTO. To measure turning radius, the full width of pavement of both lanes of traffic shall be included, exclusive of shoulder areas. Minimum turning radius shall be required from both directions of the intersecting road, unless that road is a dead-end.

(a) Road Design

1. Sight Distance

- a. Vehicle movements on road.** The road shall be designed to achieve a sight distance in the range indicated on the **Road Classification Standards Table** measured from a point 3 ½ feet above the pavement to a point 6 inches above the pavement. Sight distance shall be compatible with the design speed chosen. The maximum sight distance range shall not be exceeded without reasonable justification which shall be presented by the applicant. Isolated interruptions of minimal time duration in sight distance due to obstructions, such as a single tree, shall not be included in the measurement of sight distance.
- b. Side road and commercial driveway entrances .** The sight distance for a side road or commercial driveway entering onto a second road shall be measured from an eye point located 15 feet behind the edge of traveled way of the side road or drive at an elevation of 3 ½ feet above the finished grade surface to a point 4.25 feet above the paving in the centerline of the travel lane approaching the intersection. Where unavoidable obstructions are encountered at the 15 foot setback, the point of eye may be moved to a point no closer than 10 feet from the traveled way.
The sight distance shall be based on a minimum 7 second visibility time considering the approach vehicle speed to be the 85th percentile of actual measured speed with a sample large enough to be statistically valid or if such measurements are not obtained and validated shall be 110% of the posted speed limit. If the intersection can be located to achieve a 10 second visibility time, the Board may require such location to enhance safety. If truck traffic leaving the side

road or drive exceeds 30% of the total traffic volume, the 10 second visibility time shall be mandatory.

- c. **Single Family drive entrances** . The Board shall require the sight distance for a single family driveway entry onto a road to meet the requirements in the **Road Classification Standards Table**.
2. **Changes in Direction** . At all changes in alignment, road sidelines shall be connected by horizontal curves. Radii of curves and lengths of tangents between curves shall be consistent with the **Road Classification Standards Table**, and such radii shall not be less than 20 feet for all inside corners. All changes in slope shall be connected with vertical curves whose length shall be consistent with the **Road Classification Standards Table**. When the degree of curvature exceeds 2 degrees on rural connector, collector, or arterial roads, the curves shall be super-elevated to meet the criteria established by AASHTO, 1984 Edition or as the same may be revised or amended.
3. **Traveled Way** . Every traveled way shall maintain a constant width and shall be centered in its right-of-way. No waiver of this requirement shall be granted except in writing by the Town Manager or by the Planning Board, and only before the start of construction of the road bed.
4. **Shoulders** . The width of shoulders and surfacing shall be determined by reference to the **Road Classification Standards Table**. The road lanes shall be striped to provide a traveled way in compliance with the **Road Classification Standards Table**.
5. **Sidewalks** . Sidewalks shall be 5 feet wide and shall be separated from the traveled way by a grassed esplanade in accordance with the **Road Classification Standards Table**. When locating the sidewalk, a one (1) foot wide buffer strip shall be preserved along the right-of-way between the back edge of the sidewalk and the right-of-way. Sidewalks shall be required on one side of the road and notwithstanding Sec. 16-3-5, shall not be waived by the Planning Board. The design of a Rural Connector shall include a sidewalk path within ten feet of the outside edge of the right-of-way. The sidewalk path shall be field located to avoid significant vegetation. (Revised eff 12/10/03)
6. **Road Signs** . Road signs shall be installed by the Public Works Department, unless the applicant desires alternative means of street identification. Any alternative method must be approved by the Planning Board.
7. **Road Trees** .
 - i. Each road shall be designed to include, within the right-of-way, at least one tree for every forty (40) feet of road frontage but not less than 2 trees per lot. All trees shall comply with tree species and size standards approved by the Town Tree Warden. Existing trees within the right-of-way which have been preserved may be counted toward this requirement if the species, size, preservation measures, and post-construction condition of the trees are approved by the Tree Warden.

- ii. Landscaping including trees and other plant materials shall be required in the center island of a cul-de-sac. (Revised eff. 12/10/03)

8. Curbing .

- i. Curbing shall consist of granite, or bituminous concrete; design and choice of materials for curbing shall be based upon the anticipated use of the road involved and shall be subject to the approval of the engineer and the Public Works Director. Curbing shall be required to aid in slope stabilization. (Revised eff 12/10/03)
- ii. At road intersections, all curbing shall be granite and have a radius of at least 25 feet, unless otherwise approved by the engineer. Granite curbing specifications shall be six inch by eighteen inch vertical or eight inch by twelve inch sloped curb as required by the Director of Public Works.

9. Dead-End Roads . [Revised Effective 6/12/91 i.-iv]

- i. Dead-end roads shall not be longer than 2,000 feet in length and shall not serve more than 20 dwelling units. The maximum length, the maximum number of dwelling units and the mandatory requirements of dead-end roads shall not be waived by the Planning Board, notwithstanding the waiver provision in Sec. 16-3-5. [Rev. eff. 7/13/94]
- ii. Any dead-end road in excess of 1,000 feet in length shall meet mandatory requirements for the entire length of the dead-end road. Mandatory requirements shall include (1) the placement of all utilities underground, (2) the dedication to the town of a fifty foot wide right-of-way, and (3) a minimum pavement width of 22 feet. (revised effective 12/10/03)
- iii. The Planning Board may require improvements such as (1) the placement of sidewalks to town specifications, (2) limited clearing of the right of-way with the advice of the tree warden on the stability of adjacent tree growth, (3) the provision of an emergency access lane with a minimum width of 18 feet and (4) a minimum esplanade width of 6 feet for divided entrances.
- iv. A dead-end road shall be measured from the end of the existing or proposed dead-end road to the closest intersecting through road. The measurement shall include proposed road(s) and existing road(s), public or private, whether within or beyond the limits of the proposed subdivision. The length of the road shall be measured from the center line of the closest through road, along the center line of the dead-end road to the end of pavement or traveled way. Divided entrances shall be allowed only if they provide direct access to arterial roads as classified by the town. [Rev. eff. 7/13/94]

- v. All dead-end roads shall end in a cul-de-sac or a T-shaped turnaround and be designed according to the dimensions shown on the attached diagrams. All cul-de-sacs shall be so designed that water will drain from all portions into a storm water drainage system. The interior of all cul -de-sacs shall be neat and orderly, and shall either be left in its natural condition or be graded, loamed and seeded. Granite monuments shall be installed by the developer at the intersection of each side of the road with the cul-de-sac and at the radius point of the cul-de-sac, as shown in the cul-de-sac diagrams.

A T-shaped turnaround may be used, only after a written approval of its location and design by the Director of Public Works has been provided, to be constructed as follows:

All T-shaped turnarounds shall be paved and at no time shall any portion of the turnaround be incorporated into a private driveway, a private road or any access road. All T-shaped turnarounds shall be posted with “No Parking” signs by the developer with approval of the Public Works Director. Any temporary turnaround must be paved.

10. Intersection Entry Grades

- a. Roadway grades approaching an intersection shall not exceed 3% for a distance of 50 feet from the edge of paving of the road being entered.
- b. Driveway entrance grades shall meet the following criteria:
 - High Volume Commercial Drives: 3% Max for 30 feet
 - Low Volume Commercial Drives: 4% Max for 20 Feet
 - Single Resident Drives: 6% Max for 10 Feet

11. Private Road. A private road shall enter a road at the level of the edge of the traveled way, and shall have a slope of 3% or less within the right-of way. The first 50’ of a private road from the edge of the road shall be paved. A private road shall be constructed in accordance with the right-of-way width, gravel base, traveled way width and monumentation of a local road. The Planning Board may require that a road be constructed to public road standards; further the Planning Board shall require dedication of the roads as public rights-of-way if there is potential for future development that could be accessed through the proposed subdivision.

12. Monuments. A four inch square granite monument shall be set at each point of curvature and angle point on both sides of every road and at every property line intersection. A surveyor’s pin shall be set at each property line corner. Except with the permission of Public Works Director, all monumentation shall set flush with existing grade. At road intersections and at locations where monuments on one road line would fall within 200 feet of each other, the Public Works Director may reduce this requirement provided that the reduced monumentation is adequate for road line surveys. (Revised eff. 12/10/03)

13. Drainage . All roads shall have an underground enclosed drainage system, and no surface drainage shall be conveyed or diverted across a traveled way. (Revised effective 12/10/03)

14. Road Jogs . Road jogs at intersections with centerline offsets of less than 125 feet shall be avoided. At intersections and common boundaries of subdivisions, roads shall be continuous and in alignment with existing roads if possible. Roads shall be laid out so as to intersect as nearly as possible at right angles, and no road shall intersect any other road at less than a 60-degree angle.

(b) Road Construction

1. Clearing

- i. The construction area shall be selectively cleared of all trees, brush and vegetation only as necessary for construction of the roadway, shoulder, utilities and any drainage ways as approved by the Board. Clearing provisions shall be accomplished in accordance with the most recent revision of the Standard Specifications of the Maine Department of Transportation, Section 201.
- ii. Limits of clearing shall be marked in the field and inspected by the Town Engineer prior to any clearing or grubbing of the site. In a Rural Connector, a 10” wide strip shall be preserved at the edge of the right-of-way, where a sidewalk path may be placed. The ten foot wide strip shall be retained in a natural state and serve as a buffer, although trimming may be allowed to preserve scenic views.

2. Grading to Subgrade

- i. The roadway shall be brought to subgrade through the process of excavation and placement of fill. Such earthwork shall be accomplished in compliance with the technical provisions of Section 203 of said MDOT Specifications. Blasted ledge, which is, less than fourteen (14) inches in any dimension, may be used as fill up to a level one foot six inches below subgrade, and shall be mixed with sufficient finer material to make a firm, stable embankment. Revised eff. 12/10/03)

3. Base Gravel for Roadways & Sidewalks

- i. Aggregate gravel base course shall be a minimum of 1 foot 6 inches in depth. When subgrade materials are marginal, the Town Engineer may require additional base gravel. The lower 12 inches of material shall conform to the requirement of Section 703.06 (b). Types D or E of the said MDOT Specifications, except that no particle of rock shall exceed 3 inches as determined by a 3 inch square mesh sieve.
- ii. The upper 6 inches of material shall conform to the requirements of Section 703.06 (a). Types A and B of the said MDOT Specifications except that Maximum particle size for Type B shall be 3 inches.
- iii. The base gravel shall be placed and compacted in accordance with technical requirements of Section 304 of said MDOT Specifications. Compaction tests

shall be taken at a minimum interval of every 50 linear feet along the roadway for each lift of material placed. Retesting of any failed areas must be conducted after remedial action has been accomplished. Additional compaction tests may be required by the Public Works Director.

- iv. Gravel for sidewalk base shall be eight inches in depth and shall meet the requirements of Section 703.06 (a), Types A or B, placed in one lift compacted to 95% of optimum density.
- v. The base of the esplanade located between the road and the sidewalk shall not be filled with gravel. The underlying material under the loam layer shall be common borrow or a similar material conducive to tree growth. The maximum grade of the esplanade cross-slope shall be 2%.

4. Paving.

- i. Paving shall be of bituminous concrete meeting the requirements of Section 401 and 403 of said MDOT Specifications. Placement of pavement shall conform to MDOT Specifications (Section 401). Sidewalk pavement shall be placed in two 1” lifts using “D” mix. Pavement thickness shall be as follows:

	Base Course ("B" Mix)	Surface Course ("C" Mix)	Surface Course ("D" Mix)	Total
Arterial	2"	1 - 1/2"	--	3 1/2 "
Collector	2 "	1 - 1/2"	--	3 1/2"
Rural Connector	2 "	1 - 1/2"	--	3 1/2"
Feeder	2 "	1 -1/2"	--	3 1/2"
Local Roads	2 "	1 -1/2"	--	3 1/2"
Sidewalks	--	--	2 "	2 "

(Table revised 12/10/03)

- ii. The base course shall be Gradation B as defined in Section 703.09 of said MDOT Specifications. Surface course shall be Gradation C. Sidewalk paving shall be Gradation D.
- iii. Placement of all paving shall be in compliance with the technical requirements of Section 401 of said MDOT Specifications.
- iv. Driveway entrances shall be paved to the road line meeting the criteria for minor road paving.
- v. Where bituminous curbing is to be placed, the paving shall extend 6 inches beyond the back of curb to serve as a curb platform.

5. Curbing Bituminous concrete curbing shall be placed in accordance with Section 609 of the said MDOT Specifications. Curbing shall meet the requirements of

Section 712.36 of said MDOT Specifications. The curb cross section shall be of the low profile berm curb type and shall be placed on top of base course "B". (Revised eff. 12/10/03)

- 6. Stone Fill, Riprap, Stone Ditch Protection.** When required for erosion control, stone fill, riprap and stone ditch protection shall be placed in accordance with Section 610 of the said MDOT Specifications.
- 7. Sodding - Erosion Control Mesh**
 - i. Where required to prevent erosion and when indicated on the plans, sod shall be placed in accordance with the technical requirements of Section 626 of said MDOT Specifications.
 - ii. When required to prevent erosion and where indicated on the plans, erosion control mesh shall be placed in accordance with the technical requirements of Section 6117 of said MDOT Specifications.
- 8. Seeding**
 - i. All exposed slopes and areas not to be paved shall be seeded in accordance with the technical requirements of Section 618 of said MDOT Specifications. Seeding Method 1 shall be used.
 - ii. Mulch shall be applied to all seeded surfaces in accordance with the technical requirements of Section 619 of said MDOT Specifications.

Road Classification Standards Table

	Right of Way	Traveled Way	Total Width of Pavement	Width Unpaved Shoulder	Sight Distance	Design Speed	Sidewalk	Esplanade	Center Line Radius
ARTERIAL (unpaved shoulders)	52'	28'	30'	2'	200-400	30-45	5' (1)	5'	300-800
ARTERIAL (paved shoulders)	52'	28'	36'	0'	200-400	30-45	5' (1)	5'	300-800
COLLECTOR (unpaved shoulders)	50'	24'	26'	1'	200-250	30-35	5' (1)	6'	300-400
COLLECTOR (paved shoulders)	50'	24'	26'	0'	200-250	30-35	5' (1)	6'	300-400
RURAL CONNECTOR	66'	24'	26'	4'	200-250	30-35	5'	7'	300-400
FEEDER	50'	24'	24'	3'	150-200	25-30	5'	5'	150-300
LOCAL	50'	22'	22'	4'	125-150	20-25	5'	6'	125-150
(1) Either sidewalk or bikeway. Width should increase for dual purpose									

Table Revised eff. (12/10/03)

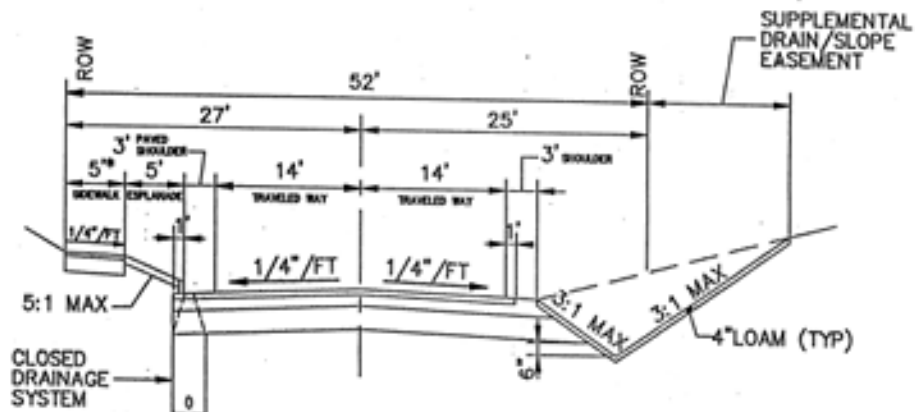

• SEE ROAD CLASSIFICATION STANDARDS TABLE

ARTERIAL (UNPAVED SHOULDERS)
NOT TO SCALE

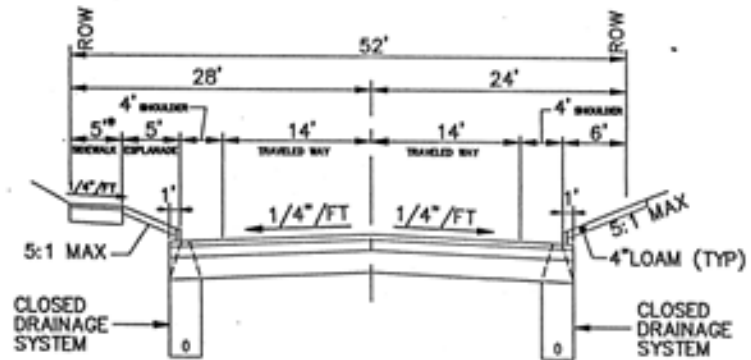

• SEE ROAD CLASSIFICATION STANDARDS TABLE

ARTERIAL (PAVED SHOULDERS)
NOT TO SCALE

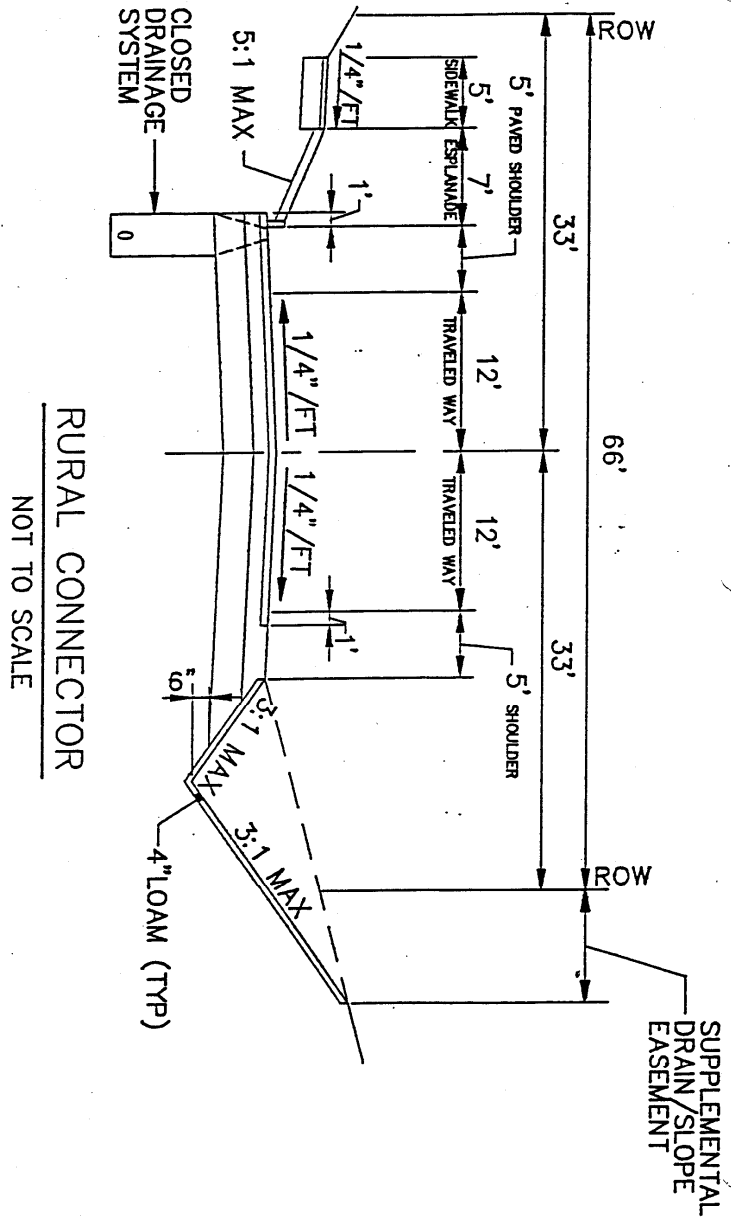

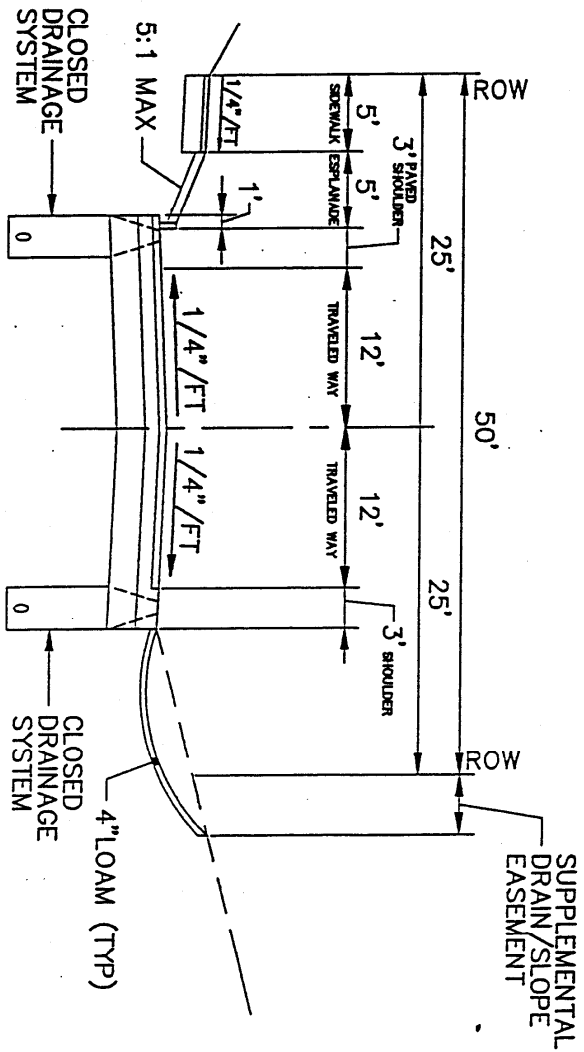

FEEDER
 NOT TO SCALE

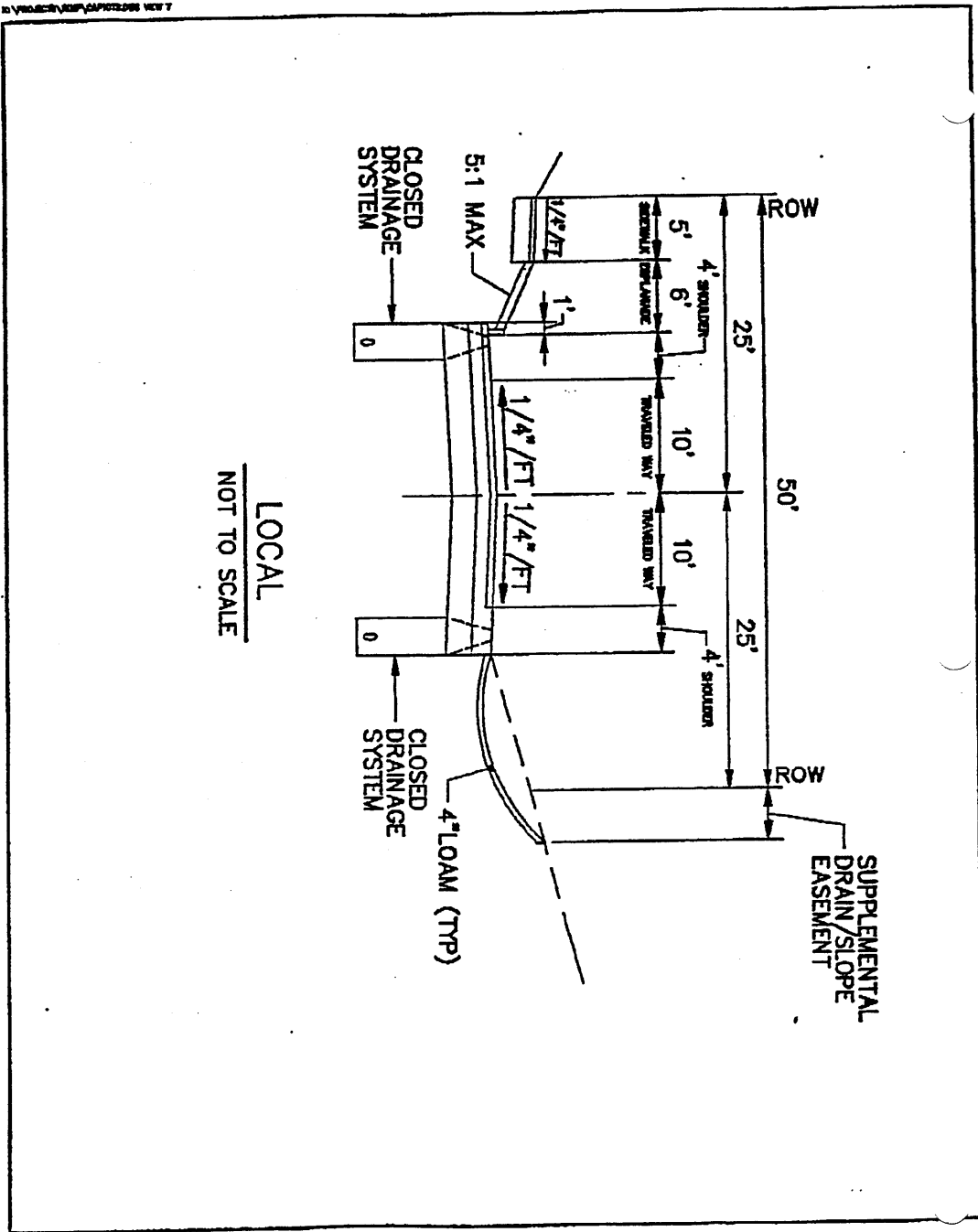

LOCAL
NOT TO SCALE

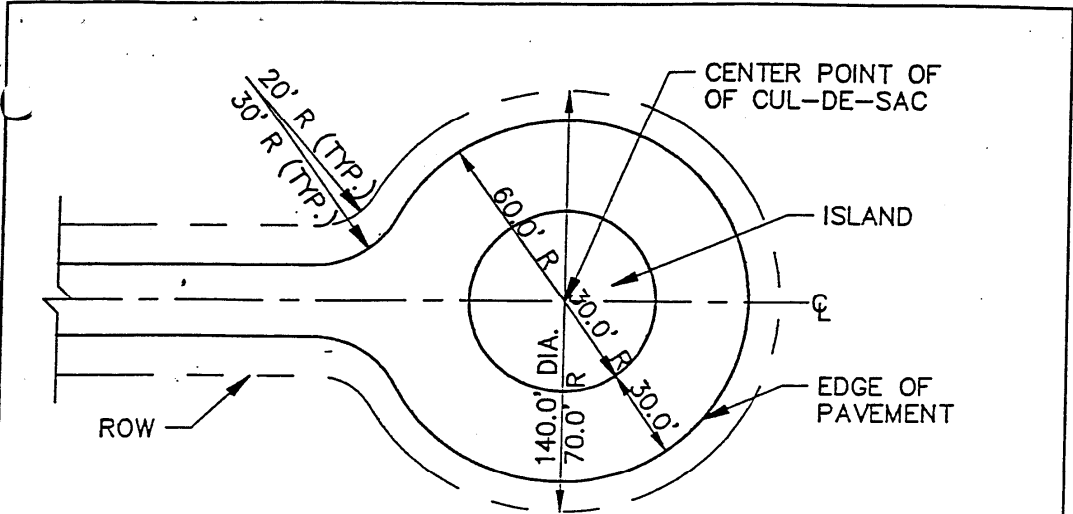

MINIMUM DIMENSIONS
CUL-DE-SAC- WITH ISLAND
 NOT TO SCALE

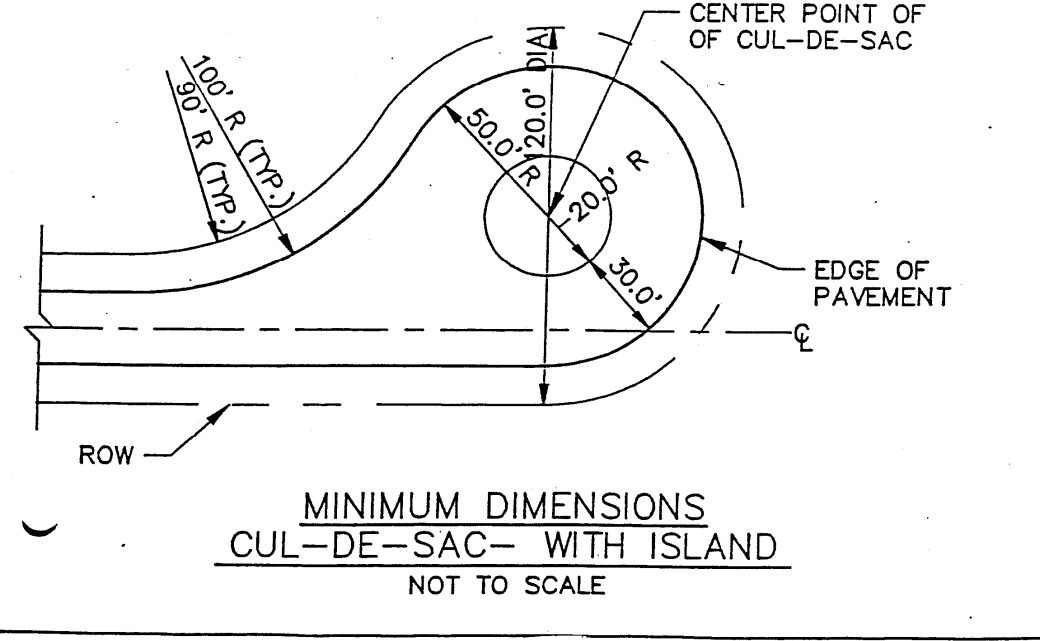

MINIMUM DIMENSIONS
CUL-DE-SAC- WITH ISLAND
 NOT TO SCALE

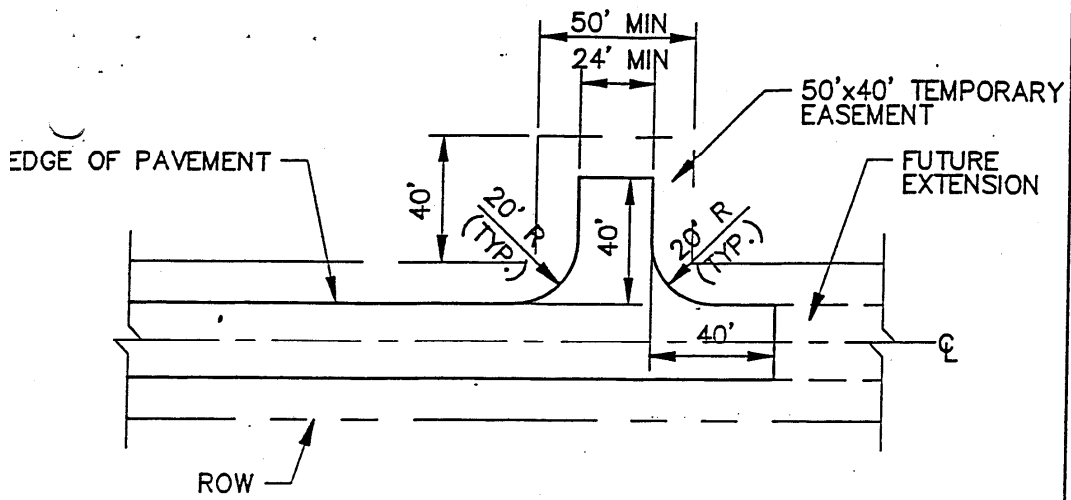

ALTERNATE 1

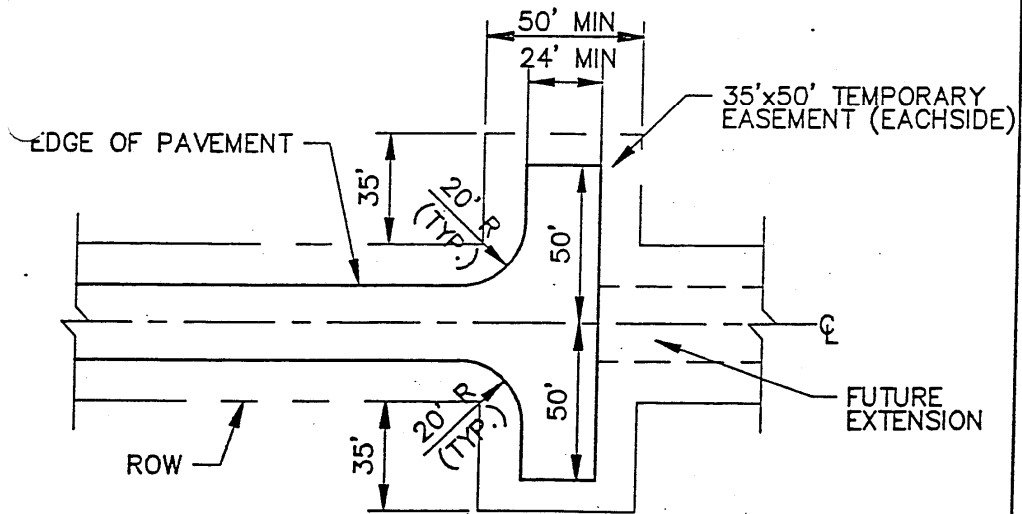

ALTERNATE 2

MINIMUM DIMENSIONS FOR TURN-AROUNDS
NOT TO SCALE

Sec. 16-3-3. Design of Other Improvements

(a) Storm and Surface Water Drainage

1. Storm water collection and transport systems shall be designed to carry a 25 year return frequency flow without surcharge.
2. Ditches, where permitted, on the approved plans shall have a slope of at least 2% and side slopes not exceeding 3:1. Where required to prevent erosion, ditches shall be riprapped, sodded, or otherwise protected.
3. Storm drain pipelines and culverts shall be installed in accordance with the technical requirements of Section 603 of said MDOT Specifications. All pipes shall be designed to withstand earth backfill plus H-20 wheel loadings. Trench backfill over drain lines within the paved way shall be compacted to 95% of optimum density. Outside of paved areas backfill shall be compacted to 90% of optimum density.
4. When required to assure a stable subbase, rigid perforated underdrain pipe shall be installed in accordance with the technical requirements of Section 605 of said MDOT Specifications. Coiled underdrain pipe will not be permitted. (Revised eff. 12/10/03)
5. Manholes and catch basins on storm drain lines shall meet the technical requirements of Section 6045 of said MDOT Specifications. Shop drawings for the units desired for use shall be submitted to the Town Engineer for approval prior to placement.
6. It is specifically noted that all drainage facilities must also comply with the requirements of the Town Storm Water Management Ordinance.

(b) Underground Utility Lines

1. All sanitary sewer lines and appurtenances shall be constructed in accordance with the requirements of the Sewage Ordinance, particularly Sec. 15-1-6 and 15-1-7.
2. Any road to be accepted shall be served by a water main if said road joins a road containing a water main. No water main shall be less than 8" in diameter unless the fire department and the Planning Board certify in writing that a water main less than 8" in diameter will furnish adequate water service for the road to be accepted and for any future extension of said road.
3. All underground utility mains shall be installed before the gravel surface is placed; and, if possible utility service lines to individual lots shall be installed before gravel surface is placed.
4. Backfill materials for all underground utilities shall be compacted to 95% of optimum density under paved areas and to 90% of optimum density under non-paved areas.

Sec. 16-3-4. Additional Standards

(a) **Right-of-Way.** The Planning Board with the advice of the engineer may require rights-of-way wider than those set forth in the **Road Classification Standards Table**, in order to satisfy the purposes of this Ordinance.

(b) **Reserved**

(c) **Sewers .** Upon the advice of the engineer, the Town Council may require a applicant to construct storm or sanitary sewers at a greater depth or of larger diameter than is required to serve the area being subdivided, when said greater depth or larger diameter is deemed necessary to provide proper service for adjacent areas.

Sec. 16-3-5. Waivers Where the Planning Board finds that undue hardship, practical difficulties or restriction upon imaginative and otherwise desirable design may result from strict compliance with this Ordinance, it may waive one or more of the requirements of this Ordinance, in favor of a proposed alternative upon a showing that, as compared with strict compliance, such alternative (1) will not create more hazardous traffic conditions or less sanitary sewage disposal conditions than strict compliance, (2) will provide more varied and imaginative subdivision layout and design, (3) will secure substantially the standards of road design and construction required by this Chapter and the Zoning Ordinance, and (4) will not have the effect of nullifying the intent and objectives of the Comprehensive Plan or this Chapter; provided that in granting such waiver the Planning Board may impose such conditions as they deem necessary to secure the foregoing objectives.

Sec. 16-3-6. Legal Provisions

(a) **Appeals .** All appeals from decisions of the Planning Board under the subdivision regulations and the Zoning Ordinance shall be taken within 30 days following the date of any such decision in accordance with the provisions of Rule 80B of the Maine Rules of Civil Procedure. This procedure shall apply whether or not the appeal involves issues requiring an interpretation of the Zoning Ordinance.

(b) **Applicability of Road Requirements.** The provisions of the subdivision regulations shall serve as a guide to, but shall not be binding upon, any state, county or municipal body or authority, which may lay out, alter, widen or improve any public way in accordance with the applicable statutes. These subdivision regulations shall not apply to any roads within the Town for which road profiles had been approved by the engineer prior to March 13, 1968, which were under actual construction as of March 12, 1968 and which had been completed not later than October 14, 1968.

(c) **Amendments to the Subdivision Ordinance .** This ordinance may be amended by the Town Council following the procedure outlined in Sec. 19-4-9 of the Zoning Ordinance.

Appendix A

Minor Subdivision Submission Requirements

A. The subdivision plan for a Minor Subdivision shall consist of fifteen (15) copies of one or more maps or drawings drawn to a scale of not more than forty (40) feet to the inch, which shall be legibly reproduced on a durable material or clearly drawn in ink on mylar and the size of the sheets shall in no case be larger than 24 x 36 inches but may be smaller at the discretion of the developer. (Revised eff. 12/10/03)

Such sheets shall have a margin of two (2) inches outside of the border lines on the left side for binding and a one (1) inch margin outside the border along the remaining sides. Space shall be reserved thereon for endorsement by all appropriate agencies. The application for approval of a Minor Subdivision shall include all the following information:

1. Proposed name of the subdivision or identifying title, and address of record owner and applicant, names of adjoining property owners, and evidence of right, title or interest in the site of the proposed subdivision.
2. The date of submission, north point, graphic map scale, name and address of record owner and applicant, and names of adjoining property owners.
3. Locations, widths and names of existing, filed or proposed roads, easements, and building lines pertaining to the proposed subdivision and to the adjacent properties.
4. The boundaries and designations of zoning districts, parks and other public spaces.
5. Location Map, showing the relative location of the proposed project in relation to surrounding neighborhoods or areas of the Town.
6. An actual field survey of the boundary lines of the tract, giving complete descriptive data by bearings and distances, made and certified by a licensed land surveyor. The corners of the tract shall be located on the ground and marked by monuments as herein required, and shall be referenced as shown on the Plan. The survey plan shall show dimensions of area and building envelope of each proposed lot.
7. Sufficient data to determine readily the location, bearing and length of every lot line, and boundary line and to reproduce such lines upon the ground. Where practical these should be tied to reference points previously established.
8. The survey of the outside boundaries of the tract and the computation of the lot lines shall be performed to an accuracy of one foot in 5,000 feet. If requested by Planning Board, the surveyor shall furnish copies of computation sheets for outside boundaries showing:
 - A. Sketch of traverse line;
 - B. Closures;
 - C. Adjustments;

- D. Coordinates; and
 - E. Computation of outside boundaries.
9. Contour lines at intervals of two (2) feet or at such intervals as the Planning Board may require, based on United States Geological Survey datum, referenced to mean sea level. Surface drainage patterns including drainage channels and watershed areas shall be shown.
 10. A soils report identifying the soils boundaries and names in the proposed development with the soils information superimposed upon the plot plan in accord with the USDA Soil Conservation Service National Cooperative Soil Classification. The Board may require a high intensity soil survey prepared by a soil scientist certified by the State of Maine which will identify changes in soils conditions down to one-eighth of an acre, along with detailed map unit descriptions. A lot-by-lot soils suitability determination for housebuilding with septic sewage disposal may also be required by the Planning Board.
 11. All on site public or shared sewage and water supply facilities shall be shown and designed to meet the minimum specifications of these standards and all pertinent state and local ordinances. Compliance shall be stated on the Plan and signed by a licensed site evaluator. If a private sewage disposal system is proposed, location and results of tests to ascertain subsurface soil and ground water conditions and depths to maximum ground water level. A completed HHE 200 form must be submitted with the application for approval as well as designs and location of any culverts which may be required.
 12. A surface drainage plan or stormwater management plan, with profiles and cross sections drawn by a professional engineer, registered in the State of Maine, showing preliminary design of all facilities and conveyances necessary to meet the stormwater management standards as set forth in this ordinance.
 13. Statement of Technical and Financial Capability, including a list of the applicant's development consultants, a description of all prior development projects, and a letter of firm financial commitment from a bank or other source of financing. In the case where the applicant asserts that public disclosure of confidential financial information may prove detrimental to the applicant or the project, the applicant may substitute a recommendation from the Town Manager that the applicant has adequate financial capability to complete the project.
 14. Electrical facilities.
 15. A copy of such covenants or deed restrictions as are intended to cover all or part of the tract.
 16. Any other data as determined by the Planning Board to ascertain compliance with this Ordinance.

17. There shall be submitted to the Board with the Final Plan:
- a. Written evidence of all easements and public open space shown on the Plan to be dedicated to the Town, the development's association, or any other third party, and copies of agreements or other documents showing the manner in which these spaces are to be maintained.
 - b. Written evidence that the Town Manager and the Town Attorney are satisfied with the legal sufficiency of the documents referred to in Paragraph (a) above when review is deemed necessary by the Board. Such written evidence shall not constitute an acceptance by the municipality of any public open space referred to in this Appendix.
 - c. Written evidence of the offer and conditional municipal approval by the Town Council of all roads, sewer lines, drainage easements, proposed public open space, recreation land, and other such common areas and facilities proposed to be dedicated to the Town.
 - d. A Subdivision Plat suitable for recording which includes a prominent notation that there shall be no sale of lots, nor issuance of building permits, nor site work commenced until the required performance guarantee has been approved by the Town Manager.

Appendix B

Major Subdivision Submission Requirements

A. Preliminary Plan Maps and Information

The Preliminary Plan shall be submitted in fifteen (15) copies of one or more maps or drawings which may be printed or reproduced on paper with all dimensions shown in feet or decimals of a foot, drawn to a scale of 1 inch equals forty (40) feet; drawings not to exceed 24" x 36". (Revised eff. 12/10/03) All plans shall be accompanied by the following information:

1. Proposed subdivision name or identifying title, the name of the Town, and evidence of right, title or interest in the site of the proposed subdivision.
2. Name and address of record owner, applicant and designer of Preliminary Plan.
3. Date of plan submission, true north point and graphic scale.
4. Number of acres within the proposed subdivision, location of property lines, existing easements, buildings, watercourses and other essential existing physical features.
5. Location Map, showing the relative location of the proposed project in relation to surrounding neighborhoods or areas of Town.
6. The names of all owners of record of adjacent acreage.
7. The space standard and setback provisions of the Zoning Ordinance applicable to the area to be subdivided and any zoning district boundaries affecting the subdivision.
8. The location and size of any existing or proposed sewers and water mains, culverts, hydrants, and drains on the property to be subdivided. This shall show the connections with existing sewer or water systems. Where public water and/or sewage is not to be provided, alternative means of water supply and sewage treatment and disposal shall be shown.
9. If individual or collective private sewage disposal system(s) is (are) proposed, the location and results of tests to ascertain subsurface soils and ground water conditions, which shall be signed and numbered by a licensed site evaluator. These results shall be submitted on an HHE 200 form.
10. Location, names and present and proposed widths of existing and proposed roads, highways, easements, building lines, alleys, parks and other public open spaces both within and abutting the subdivision. Grades and road profiles of all roads, sidewalks or other public ways proposed by the applicant shall be shown.

11. Contour lines at intervals of two (2) feet or at such intervals as the Planning Board may require, based on United States Geological Survey datum and referred to mean sea level.
12. A soils report identifying the soils boundaries and names in accordance with the USDA Soil Conservation Service National Cooperative Soil Classification. The Board may require a high intensity soil survey which will identify changes in soils conditions down to one-eighth acre. A lot-by-lot soils suitability determination for housebuilding with septic sewage disposal may also be required by the Planning Board.
13. Deed reference and map of survey of tract boundary made and certified by a registered land surveyor, tied into established reference points. Deed restrictions, if any, shall be described.
14. A surface drainage plan or stormwater management plan, with profiles and cross sections drawn by a professional engineer, registered in the State of Maine, showing preliminary design of all facilities and conveyances necessary to meet the stormwater management standards as set forth in this Ordinance.
15. The proposed lot lines with dimensions, area and building envelopes.
16. The location of temporary markers adequate to enable the Board to locate readily and appraise the basic layout in the field.
17. All parcels of land proposed to be dedicated to public use and the conditions of such dedication.
18. The location of all natural features or site elements to be preserved.
19. Typical cross-sections of the proposed grading for roadways, sidewalks, etc. including width, type of pavement, elevations and grades.
20. Preliminary designs of any bridges or culverts which may be required.
21. A soil erosion and sediment control plan shall be prepared and certified by a professional geologist or professional engineer.
22. A grading and landscaping plan including natural features to be preserved.
23. Statement of Technical and Financial Capability, including a list of the applicant's development consultants, a description of all prior development projects, and a letter of firm financial commitment from a bank or other source of financing. In the case where the applicant asserts that public disclosure of confidential financial information may prove detrimental to the applicant or the project, the applicant may substitute a

recommendation from the Town Manager that the applicant has adequate financial capability to complete the project.

24. Community Impact Analysis. The Planning Board may require the applicant to conduct a community impact analysis which will consist of the following demographic features.
- a. Demographic Description. The analysis must identify the demographic market the project intends to serve, including:
 - (1) type of family;
 - (2) average family size;
 - (3) number and ages of children; and
 - (4) anticipated time period to fill all units or lots.

Associated data, such as anticipated income levels, type of employment, and projected housing costs may also be presented to support projections associated with the above demographic description.

- b. Community Impact Analysis. Utilizing the above demographic data, the applicant shall conduct analyses of the following:
 - (1) Estimated impact of traffic systems, including the impact of projects trips on flow characteristics and the impact of traffic on the immediate, existing road structures;
 - (2) Estimated impact on the school system;
 - (3) Estimated impact on public safety providers;
 - (4) Estimated impact on the public works department, including solid waste disposal;
 - (5) Estimated impact on existing storm water management systems including flow and water quality;
 - (6) Estimated impact on the recreation resources and provision of methods to meet proposed needs; 41
 - (7) Estimated impact on wildlife habitat areas;
 - (8) Impact on the stated goals and objectives of the Comprehensive Plan; and
 - (9) Any other study deemed appropriate by the Board.

Once these analyses have been completed, the applicant shall present this information and impact assessments to the Board for its review and comment.

B. Final Plan Maps and Information

Application for final approval shall be accompanied by fifteen (15) copies of final subdivision plans, drawn to scale, reproduced in the size and manner of preliminary plans, showing:

1. All information required to be shown on the preliminary plans, with all amendments required by the Planning Board and other reviewing agencies and those suggested by the Board and adopted by the applicant, except topography unless changed from the

preliminary plans and except soils data, in accurate final form with distances to an accuracy of one foot in 5,000 feet;

2. Field survey of the subdivision perimeter complete with courses and distances made and certified by a registered land surveyor whose name, number and seal shall be shown, with all corners marked by monuments set as prescribed herein and with sufficient data to determine readily the location, bearing and length of every lot and boundary line and to reproduce such lines on the ground;
3. Proper designation of all spaces to be reserved for or dedicated to the Town or other third party or to be reserved by the applicant, and the numbering of all subdivision lots;
4. Written evidence of the issuance of all permits, licenses and approvals required for the subdivision from any federal, state or other local agency;
5. Written evidence of an adequate supply of domestic water, in the form of (i) approval by the Portland Water District, (ii) approval by the appropriate state agency of any proposed central water supply system, or (iii) approval by a registered Maine engineer if individual wells are to be used for building sites, in which latter case the board may also require reports by the appropriate state agency of the results of all water quality tests;
 6. Written evidence of (i) the availability of public sewage service for some or all of the lots; or (ii) compliance with the clustered sewer system provisions of Chapter 15, review by the Town Engineer, receipt of a letter from the Maine Department of Human Services, and written approval of the local plumbing inspector; or (iii) municipal approval of the proposed sewage disposal systems, to be designed and installed in compliance with the Town Sewer Ordinance, and which shall require the review and approval by the Town Engineer and the building inspector of the subsoils land of said sewage disposal arrangement; and
7. Written evidence of (i) the offer and conditional municipal approval of all roads, sewer lines, drainage easements, proposed public open space, recreation land, and other such common areas and facilities proposed to be dedicated to the Town; or (ii) satisfactory agreements or other documents showing the manner in which private roads, sewer lines and systems, drainage ways, open space, recreation land, and other such common areas and facilities are to be maintained. Written agreements of a dedication to a third party other than the Town must also be submitted and deemed satisfactory by the Board.
8. A Subdivision Plat suitable for recording which includes a prominent notation that there shall be no sale of lots, nor issuance of building permits, nor site work commenced until the required performance guarantee has been approved in accordance with Sec. 16-2-4 (c)(7)(A).

Subdivision Ordinance Appendix C

The following trees are recommended for planting to meet the road tree requirements. Alternative species may also be acceptable upon approval of the Tree Warden, unless specified by the Planning Board. The list includes the scientific and common tree name, minimum required caliper at the time of planting, expected height at maturity and comments. The comments refer to tree characteristics of water and salt tolerance.

Scientific	Common	Size	Height	Comments*
Acer campestre	Hedge Maple	2"	45'	D,M
Acer saccharum	Sugar Maple	2"	80'	WD
Acer pseudoplatanus	Planetree maple	2"	60'	WD,H
Acer rubrum	Red Maple Cultivars	2"	60'	W,M
Betula alleghaniensis	Yellow Birch	2"	50'	W
Betula nigra	Heritage River Birch	2"	60'	W
Carpinus caroliniana	American Hornbeam	2"	30'	W
Cercidiphyllum japonicum	Katsura	2"	60'	W
Chionanthus virginicus	Fringetree	2"	30'	W
Cladrastus kentuckea	Yellowwood	2"	60'	W
Corylus colurna	Turkish Filbert	2"	50'	D
Crateagus spp.	Hawthorne	2"	30'	D
Ginkgo biloba	Maidenhair Tree	2"	60'	D,M
	Cultivars			
Maackia amurensis	Maackia	2"	40'	W
Nyssa sylvatica	Tupelo	2"	60'	W
Platanus acerfolia	London Plane	2"	75'	W
Quercus bicolor	Swamp White oak	2"	55'	W
Quercus rubra	Red Oak	2"	75'	D
Sorbus alnifolia	Korean Mountain Ash	2"	35'	D,M
Syringa reticulate	Japanese Tree Lilac	2"	30'	D,M
Zelkova serrata	Zelkova	2"	50'	W

* W= Wet, D=Dry, WD=Well Drained, M=Moderate Salt Tolerance and H= High Salt Tolerance

All trees shall be planted in accordance with the Planting Specifications of the Cape Elizabeth Comprehensive Street Tree Plan.